

BARDSTOWN HISTORIC DESIGN REVIEW MANUAL



2008

Bardstovn Historical Review Board
Joint City-County Planning Commission of Nelson County
PO Box 402, Old Courthouse Building, 2nd Floor
One Court Square
Bardstovn, Kentucky, 40004
www.ncpz.com

ACKNOWLEDGMENTS

Bardstown City Council

Richard Heaton, Mayor
Fred Hagan, Member
Francis Lydian, Member
Thomas D. Reed, Member
John Royalty, Member
William S. Sheckles, Member
Robert L. Simpson, Member

Joint City-County Planning Commission of Nelson County

Mike Zoeller, Magisterial District #2, Chair
Linda Wells, Vice-Chair
Mark Mathis, City of Bardstown, Secretary/Treasurer
Kenneth Brown, City of Bloomfield
Theresa Cammack, Magisterial District #3
Wayne Colvin, Magisterial District #5
Andy Hall, City of New Haven
Todd Johnson, City of Bardstown
Mary Ellen Marquess, City of Fairfield
Roland Williams, City of Bardstown
Carolyn Welch, Magisterial District #4
Janet L. Johnston, Director

Bardstown Historical Review Board

Don Parrish, Chair
Joe Buckman
Mary Carey
Beth Hawkins
Julie Wilson
Pen Bogert, Preservation Administrator

Project Consultants

Thomason and Associates
P. O. Box 121225
Nashville, TN 37212

The City of Bardstown participates in the Certified Local Government (CLG) program administered by the National Park Service and the Kentucky Heritage Council.

We thank the Metro Louisville Historic Landmarks Commission for permission to use a portion of graphics and text from their Design Guidelines.

TABLE OF CONTENTS

SECTION 1: INTRODUCTION	1
Purpose	1
Overview of Historic Preservation in Bardstown	1
Overview of Local Historic Designation	1
Difference between National Register and Local Historic Designations	3
Benefits of Local Historic Designation	4
Bardstown Historical Review Board	6
Design Guidelines	6
Design Review Process	9
Enforcement	11
SECTION 2: A BRIEF HISTORY OF BARDSTOWN	12
SECTION 3: ARCHITECTURAL STYLES	15
Vernacular Houses: Late 1700s . 1890.	16
Federal: 1780 . 1820	18
Greek Revival: 1825 . 1860	19
Italianate: 1840 . 1885	20
Queen Anne: 1880 . 1910	21
Folk Victorian: 1870 . 1910	22
Colonial Revival: 1880 . 1955	23
Tudor: 1890 . 1940	24
Neoclassical: 1895 . 1950	25
Craftsman: 1905 . 1930	26
SECTION 4: RESIDENTIAL DESIGN	27
Accessory Structures	28
Architectural Details and Features	30
Awnings	32
Chimneys	33
Decks	34
Doors	35
Fences and Walls	40
Foundations	42
Gutters and Downspouts	43
Landscapes	44
Lighting	45
Masonry	46
Mechanical Equipment, Trash Collection Areas, and Outdoor Storage Areas	49
Paint	50
Porches, Steps, and Stairs	53
Roofing	58
Shutters	61

Siding and Trim	62
Signs	64
Site	65
Streetscape	67
Windows	69
SECTION 5: RESIDENTIAL - NEW CONSTRUCTION	72
SECTION 6: NON-RESIDENTIAL DESIGN	77
Architectural Details and Features	78
Awnings	80
Doors	81
Fences and Walls	84
Gutters and Downspouts	85
Lighting	86
Masonry	87
Mechanicals	91
Paint and Paint Colors	92
Rear Elevations	94
Roofs	95
Safety and Accessibility	97
Signs	98
Site	100
Storefronts	101
Streetscapes	105
Windows	107
SECTION 7: NON-RESIDENTIAL – NEW CONSTRUCTION	109
SECTION 8: ECONOMIC HARDSHIP	114
SECTION 9: DEMOLITION	117
SECTION 10: CONDITIONAL USE	118
APPENDIX A: MAP OF LOCAL HISTORIC DESIGNATION	119
APPENDIX B: MAP OF NATIONAL REGISTER HISTORIC DISTRICT	120
APPENDIX C: DEFINITIONS	121
APPENDIX D: PRESERVATION RESOURCES	128
APPENDIX E: THE SECRETARY OF THE INTERIOR'S STANDARDS FOR REHABILITATION	129

SECTION 1

INTRODUCTION

Purpose

The Bardstown Historic Design Review Manual describes the legal basis, process, standards, and guidelines for protecting and rehabilitating Bardstown's historic areas, buildings, and structures.

This manual is for officials and citizens, and it is a guide for planning and implementing preservation and rehabilitation projects.

Information contained in this manual is not intended to override, but is to be used in conjunction with the Zoning Regulations and other applicable local, state, and federal laws, rules, and regulations. This manual is a living document. It may change over time, but the purposes should always remain the same.

Overview of Historic Preservation in Bardstown

Historic preservation is a major factor in Kentucky's community and economic development. Throughout the Commonwealth, cities and counties have enacted historic overlay zoning and incorporated historic preservation into their planning efforts. The City of Bardstown recognizes the importance of maintaining the vitality of its historic resources as part of its overall community and economic development goals.

In 1967, the City of Bardstown became one of the first communities in the nation, and the first in Kentucky, to adopt historic zoning. In 1931, Charleston, South Carolina, was the first city to designate an historic district and establish regulatory tools for protecting and preserving historic properties. Other communities, such as New Orleans in 1937 (French Quarter), San Antonio in 1939 (Prolex la Villita), Washington, D.C. in 1950 (Georgetown), followed and implemented regulatory protection for historic districts. According to the National Park Service, by 1965 51 communities had enacted historic zoning. During the 1960s, other communities implemented preservation programs in conjunction with the 1966 passage of the National Historic Preservation Act and in reaction to urban renewal, inappropriate modern development, and general decay of older commercial areas and neighborhoods.

After World War II and throughout the mid 1960s, Bardstown, as with other communities, experienced inappropriate and insensitive development and redevelopment, loss of significant historic structures and architectural elements, and use of inappropriate materials and colors in the historic district. In 1966, Bardstown's fervor for historic zoning resulted from the demolition of three historic buildings for the construction of a modern-design post office within the core of Bardstown's historic district. After considerable debate and consideration, the Bardstown City Council, along with Nelson County Fiscal Court, enacted a Joint Ordinance and Resolution of the City of Bardstown and the County of Nelson, Kentucky, for the Preservation of Historic and Architecturally Significant Structures and Creating a Bardstown-Nelson County Historical Commission on January 10, 1967, and January 3, 1967, respectively.

Bardstown's first historic zoning ordinance established the Bardstown-Nelson County Historical Commission, and it was an appearance ordinance providing for the regulation of only the exterior appearance of 250 historic structures within the historic district. In 1976, the ordinance evolved from an appearance to a value preservation ordinance regulating the review of exterior alteration, new construction, relocation, demolition, site alterations, landscaping, and signage. The ordinance also was amended to comply with statutory requirements for historic overlay zoning and was incorporated into the countywide Zoning Regulations. In 1985, the City of Bardstown qualified as a Certified Local Government, a program designed to promote preservation by establishing a partnership between local governments and the state historic preservation office (SHPO) and to provide technical and financial assistance for preservation programs and activities. At this time, the historic district was again expanded, and the Historical Review Board developed written design guidelines (standards and criteria) for addressing design issues and assisting property owners to ensure that exterior alteration, new construction, relocation, demolition, site alterations, landscaping, and signage are appropriate. In 1995 the historic district was expanded to its present boundary.

The Bardstown Historical Review Board, with support from the Preservation Administrator and Joint City-County Planning Commission of Nelson County, administers the historic overlay zoning regulations, as set forth in Article 15 of the *Zoning Regulations for All of Nelson County*. Today, Bardstown's local historic designations include the historic district with 485 residential, office, commercial, institutional, and public structures and sites and 7 landmarks and landmark sites. Since the inception of historic overlay zoning, the historic district has added 14 new principal buildings and only lost 16 principal buildings.

In 2007, the City of Bardstown and Joint City-County Planning Commission initiated an update of the historic design guidelines to clarify and expand the existing standards and provide for additional standards and criteria addressing new materials and other issues and concerns. The Planning Commission and City of Bardstown contracted with Thomason and Associates, a Nashville preservation planning firm, to conduct a series of stakeholder meetings and workshops and to update the design guidelines. This Bardstown Historic Design Review Manual is the final product of the 4-month project and is beneficial to the future of historic overlay zoning in Bardstown.

Overview of Local Historic Designation

Overlay zoning is an effective tool used by communities to protect specific resources from development pressures. Overlay zoning establishes an additional layer of regulations for a specific area. Overlays are zoning tools that work with the underlying zoning; they don't replace it. The base zoning regulations continue to be administered, but the overlay adds another level of regulations to be considered.

Local historic designation, or historic overlay zoning, is a proven tool for maintaining and protecting distinctive historic and architectural characteristics of areas, buildings, and structures. This designation is not an independent process. It is a zoning tool that is part of the community's overall planning and zoning process. Local historic designation consists of the identification of districts, landmarks, or landmark sites and the establishment of processes and standards for designation and design review. Local historic designation is regulatory and requires property owners to comply with additional regulations prior to alterations, demolition, relocation, or new construction. However, this proven zoning tool provides property owners and the marketplace with predictability and certainty that designated historic areas, buildings, structures, and sites will be protected and property values will be maintained.

Kentucky's enabling legislation, Kentucky Revised Statutes (KRS) 82.660-670, allows cities to adopt overlay zoning to provide for additional regulations for design standards and development within an area determined to be historic, architectural, natural, or culturally significant and that is suitable for preservation or conservation.

Bardstown's historic overlay zoning is established through Article 15 of the Zoning Regulations for All of Nelson County. The purposes of the regulations are to:

- Protect areas, structures, and sites that have special historical or architectural significance;
- Protect historic areas, structures, and sites from destruction, degradation, or encroachment;
- Encourage and promote adaptive use and rehabilitation of historic areas, structures, and sites which will lead to their continuance, conservation, and improvement;
- Encourage and promote appropriate infill development and new construction within historic areas; and,
- Promote the education, cultural, economical, and general welfare of the public and prevent creation of environmental influences adverse to such purposes.

Article 15 establishes a local review board and sets forth the processes and procedures for local historic designation, development and adoption of design standards, and consideration and approval of exterior alteration, new construction, relocation, demolition, site alterations, landscaping, and signage.

Bardstown's ordinance provides for two types of local historic designations . local historic districts and landmarks. Local historic districts are geographically defined areas comprised of a significant concentration of historic structures and sites that share common historic events, architectural features, or physical development. Landmarks are buildings, structures, objects, or sites which are identified as historic resources of particular significance. Since local historic designations are overlay zoning districts, the designation process is the same as zoning map amendments (zone changes) and requires a public hearing and recommendation by the Joint City-County Planning Commission and final action by the Bardstown City Council.

Difference Between National Register and Local Historic Designations

Unlike local historic designations that are regulatory and require the owner to obtain approval for proposed projects, National Register of Historic Places designation listing is largely honorary, and property rights do not change. The National Register of Historic Places is the nation's official list of cultural resources worthy of preservation and is part of a national program to coordinate and support public and private efforts to identify, evaluate, and protect historic and archaeological resources. Provided there is no federal funding, licensing, or permitting involved, properties listed in the National Register of Historic Places are not protected, and owners may maintain, manage, or dispose of their property as they choose. Owners of income-producing properties individually listed on the National Register or properties designated as contributing to the National Register District may be eligible for federal and state rehabilitation tax credits.

Similar to local historic designations, properties may be listed in the National Register individually or as part of a district. Individual listings are buildings, structures, objects, or sites that possess significance in American history, architecture, archeology, engineering, and culture and integrity of location, design, setting, materials, workmanship, feeling, and association. A National Register district is "a geographi-

cally definable area, urban or rural, possessing a significant concentration, linkage, or continuity of sites, buildings, structures, or objects united by past events or aesthetically by plan or physical development. A district may also comprise individual elements separated geographically but linked by association or history+(1). Within a National Register district, properties are designated as contributing or non-contributing. A contributing property is a structure, object, or site located within the district's boundaries and that has maintained its historic integrity and contributes to the district's historic associations and/or architectural or archaeological qualities. A non-contributing property is also located within the district's boundaries but does not add to the district's significance, has had significant alterations affecting its historic integrity, or, at the time of listing, was less than 50 years old. Non-contributing properties are not eligible for benefits of the National Register designation. A contributing property may be reclassified as non-contributing if significant alterations are made that adversely impact or destroy its historic integrity.

Bardstown's local historic district encompasses a National Register District and 7 individual listings on the National Register of Historic Places. Listed in 1983, the National Register district includes 198 contributing resources and 61 non-contributing resources. Individual listings include Edgewood, the Cobblestone Path, St. Joseph Basilica and the St. Joseph College District, Nelson County Jail, Old Talbott Tavern, Spalding Hall, and the John S. Kelley House. Appendices A and B show the boundaries of the local historic district and National Register district.

(1) Title 36: Section 60.3, Parks Forests and Public Property, Chapter One, Part 60. National Register of Historic Places. Retrieved 19 February 2007.

Benefits of Local Historic Designation

Local historic designation is a proven and effective tool for protecting the significant historic resources of a community. Numerous studies have been conducted to determine and explain the impacts of local preservation ordinances and design guidelines. A 2007 publication, "Historic Preservation in Kentucky," by John I. Gilderbloom, Erin E. House, and Matthew J. Hanka, provides detailed information on the benefits of preservation efforts in Kentucky, and in particular, identifies Bardstown as a leader in preservation in Kentucky. Historic overlay zoning benefits our community in many ways:

- **Historic Buildings and Sites Are Preserved**

Bardstown is fortunate to have a wide array of historic buildings dating back to the late 18th century. These buildings, along with historical features such as outbuildings, wells, and fences, represent virtually every style of American residential and commercial architecture. They are the product of an unusually strong local craft tradition and they encompass buildings used by diverse groups at all economic levels.

- **Design Review Promotes Quality of Life**

Historic preservation promotes quality of life, which is an important ingredient in economic development. Historic buildings are unique in that they differentiate one community from all others. Bardstown is known for the quality and quantity of its historic landscape. The quality of historic buildings and the quality of their preservation says much about a community's self image. A community's commitment to itself is a prerequisite for nearly all quality-of-life elements.

- **Historic Buildings Often Last Longer Than New Ones**

The life expectancy of rehabilitated historic buildings may well be longer than that of new structures. Buildings constructed in the 18th through the mid 20th centuries contain materials now diffi-

cult to acquire, and they exhibit quality craftsmanship. As a result, the life expectancy of pre-1950 buildings is generally greater than those built in recent decades.

- **Historic Preservation Supports Taxpayer Investments**

Bardstown has made an enormous investment in infrastructure, such as sidewalks, lights, water, sewer, telephone, electrical, gutters, curbs, roads, and streets. Promoting preservation of existing buildings and encouraging new construction in the historic core reinforces the use of existing public infrastructure. Commitment to revitalization and reuse of historic neighborhoods may be the most effective act of fiscal responsibility a local government can make.

- **Historic Preservation Creates Jobs**

Rehabilitation and revitalization projects create thousands of construction jobs annually, and *historic preservation creates more jobs than new construction*. Rehabilitation projects are more labor intensive than new construction. In new construction, generally half of all expenditures are for labor and half are for materials. In a typical historic rehabilitation project, between 60 and 70 percent of the total cost goes toward labor, which has a beneficial ripple effect throughout the local economy.

- **Historic Preservation Increases Property Values**

Studies across the country show that property values in designated National Register and/or local historic districts either stabilize or increase. Many times these increases are greater than surrounding neighborhoods which may have similar architecture but do not have protective historic overlay zoning. Nationwide, studies consistently illustrate that historic overlays benefit owners through higher property values and house sales.

- **Historic Preservation Benefits the City**

Bardstown recognizes that maintaining the vitality of historic areas increases its tax base, fosters economic development, and is fiscally responsible. Design guidelines provide practical assistance and direction to assure that improvements are compatible with the goals and desires of property owners and the city.

The preservation and revitalization of older neighborhoods is of greater economic benefit to a city than is the continuation of suburban development. Low-density development is much more costly than is compact development, due to the required expenditure for public infrastructure and public services. The older areas of Bardstown already possess an efficient infrastructure and services, such as sidewalks, streets, sewer, water, and street lights. Through appropriate rehabilitation of existing buildings and compatible new construction, the city's older areas contribute to a fiscally responsible approach to Bardstown's economic development.

Historic architecture attracts visitors to cities. Heritage tourism is a rapidly growing segment of the tourism industry. Bardstown has a nationwide reputation for its historic character, and design guidelines encourage rehabilitation consistent with this economic approach.

- **Historic Preservation Benefits Property Owners**

Real estate often represents an individual's largest economic asset, and property owners all want this asset to improve in value. Historic district designation and use of design review guidelines help to ensure that investment in an historic area will be protected from inappropriate new construction, misguided remodeling, or demolition.

Locally designated districts protect the overall economic value of an historic area. Every building or parcel in an historic area is influenced by the actions of its neighbors. Design guidelines provide a level playing field for all property owners because they apply consistently and equally to everyone in an historic area.

Bardstown Historical Review Board

The historic design review process is a consultative interaction between the Bardstown Historical Review Board (HRB) and owners, design professionals, and other interested individuals. The HRB consists of 5 citizen members with a demonstrated interest in historic preservation, at least 2 of whom must have training or experience in a preservation-related profession, such as architecture, history, archaeology, architectural history, planning, or related field. HRB members are appointed by the Bardstown Mayor with approval of the Bardstown City Council and serve 3-year terms. The HRB is part of the Joint City-County Planning Commission and is provided support through the Preservation Administrator and other Planning Commission staff. The HRB's business is conducted under a set of bylaws and rules of procedures. The HRB has scheduled meetings, and HRB meetings are open to the public, unless otherwise allowed by Kentucky's open meeting laws.

The HRB's powers and duties are prescribed in the provisions of Article 15 of the Zoning Regulations. Those powers and duties include:

- Conduct and maintain an inventory of historic, cultural, and archaeological resources;
- Make recommendations to the Planning Commission and City of Bardstown on all matters related to the preservation, conservation, and enhancement of structures, premises, and areas of substantial historic or architectural significance;
- Make recommendations on the designation and regulation of historic overlay zoning districts to the Planning Commission and City of Bardstown;
- Develop written design guidelines, based on the Secretary of the Interior's Standards for Rehabilitation, for reviewing the appropriateness of site and structural alterations, demolition, new construction, or relocation;
- Initiate all local nominations to the National Register of Historic Places;
- Provide technical assistance to property owners, design professionals, contractors, and other interested individuals in historic preservation; and,
- Enhance public awareness of historic preservation through educational programs, meetings, and publications.

Design Guidelines

The primary tool for historic design review is design guidelines. They are helpful, interpretative, and explanatory standards for the preservation, rehabilitation, and maintenance of historic structures and sites. These standards address design concerns and ensure that exterior alteration, new construction, relocation, demolition, site alterations, landscaping, and signage are appropriate and respect the character of the structure, site, and area.

Design guidelines are written and graphic standards that provide the basis for fair and consistent decisions in the design review process. Design guidelines are intended to assist property owners in the

maintenance, rehabilitation, and preservation of their historic properties, and, in turn, foster civic pride in the community. Design guidelines are also intended to assist design professionals, contractors, and others involved in the planning, preservation, and rehabilitation of historic structures and sites.

The basis for Bardstown's Design Guidelines, provided in this manual, is ***The Secretary of the Interior's Standards for Rehabilitation***, established in 1977 and revised in 1990 by the National Park Service. The *Secretary's Standards* are broad, general principals addressing the exteriors, interiors, materials, construction types, sizes, and occupancy of historic structures and are used for the review of rehabilitation projects involving federal funding or requiring federal licenses or permits. Local preservation commissions and boards throughout the country use these federal standards as a basis for their design guidelines and for reviewing local preservation projects. The Secretary of the Interior's Standards for Rehabilitation are provided in Appendix E of this manual and are also available, along with the more specific, ***Secretary of the Interior's Standards for the Treatment of Historic Properties with Guidelines for Preserving, Rehabilitating, Restoring, and Reconstructing Historic Buildings***, online at www.cr.nps.gov/hps/tps. or for use at the offices of the Joint City-County Planning Commission of Nelson County.

Bardstown's design guidelines were developed by the Historical Review Board (HRB), in consultation with local officials and stakeholders.

Overall Approach and Format

Bardstown's design guidelines emphasize preservation over wholesale alteration. This view is illustrated through their use of terms like *retain*, *repair*, and *protect*, and their emphasis on using matching materials and design in replacement. In its review, the HRB will use the following criteria to determine whether to grant a Certificate of Appropriateness:

- Applicants have considered retaining and repairing original or historic building features.
- If replacement is required, applicants have considered replacing elements using the same material, design, and size of the original.
- If replacement in kind is not feasible, applicants and the HRB will consider the use of substitute materials under some circumstances.

When an owner wants to replace a missing historic or original element but is unsure about its placement or appearance, physical evidence and historic photographs should be used to guide replacement.

Throughout these guidelines, a number of terms are frequently used to reflect the general approach the HRB will consider when making its decisions. These terms and their definitions include:

- **Appropriate:** Rehabilitation and new construction actions especially suitable or compatible with the design guideline standards.
- **Acceptable:** Rehabilitation and new construction actions which will be approved under most circumstances. Although these actions may not be the ideal approach to a design issue, they will meet the intent of the guidelines sufficiently to warrant approval.
- **Recommended:** Suggested, but not mandatory actions outlined in the design guidelines.

The design guidelines are concerned with all aspects of historic structures and especially with the portions of buildings visible from public view. Typically, this includes the main building façade facing the

street, which includes the most defining features of the property such as porches, primary entrances, windows, and decorative details. Rear elevations provide more flexibility for additions or alterations, since they are generally not readily visible to the public, and new construction at the rear of buildings is appropriate.

What Design Guidelines Can & Cannot Do

Reprinted from National Park Service website on "Creating & Using Design Guidelines," <http://www.nps.gov/history/hps/workingonthepast>

Guidelines can . . .

- √ Explain, expand, and interpret general design criteria in the local preservation ordinance.
- √ Help reinforce the character of an historic area and protect its visual aspects.
- √ Protect the value of public and private investment, which might otherwise be threatened by the undesirable consequences of poorly managed growth.
- √ Indicate which approaches to design a community encourages, as well as which it discourages.
- √ Serve as a tool for designers and their clients to use in making preliminary design decisions.
- √ Increase public awareness of design issues and options.

Guidelines cannot . . .

- X Serve the same legal purpose as the design review provisions of the ordinance. An ordinance is a law, but local design guidelines are typically not laws.
- X Limit growth, or regulate where growth takes place. Guidelines address only the visual impact of individual work projects on the character of a local historic district. Growth itself is a separate issue that must be separately addressed through zoning ordinances and preservation planning.
- X Control how space within a building is used. They usually deal only with the exterior, publicly visible portions of buildings, not with how interior space is laid out or used.
- X Guarantee that all new construction will be compatible with a historic area or guarantee creativity that is essential to the best sorts of sensitive design.
- X Guarantee "high quality" construction. Since materials are generally not specified in the design guidelines, the final visual results, again, cannot be guaranteed.

What Guidelines Can and Cannot Do For Your Historic District. Excerpted and adapted from Design Review for South Carolina Historic District Commissions by Winter & Co., 1988.

This manual provides design guidelines for residential and commercial properties. The guidelines appear in alphabetical order by building element. Included is guidance for common issues involving rehabilitation, new construction, sites and settings, signage, demolition, and moving buildings. Photographs of Bardstown properties and drawings are included to familiarize property owners with typical features and to illustrate the guidelines. Property owners should refer to the guidelines when planning routine maintenance, exterior or site rehabilitations, or new construction projects.

When planning changes to properties within the local historic district or to landmarks, these guidelines must be followed in order to receive a COA. The HRB will apply the guidelines more rigorously for historic buildings . defined as buildings at least 50 years old and substantially unaltered since that time . and historic features such as outbuildings and fences. Renovations made at least 50 years ago may be as significant as original building elements, and preserving the later but still historic elements should always be considered alongside options to restore original appearances. In reviewing work on non-historic buildings, the HRB's approach is to maintain or enhance their relationship and compatibility with adjacent historic buildings and streetscapes.

The Secretary of the Interior's Standards for Rehabilitation

This manual's design guidelines follow the guidelines established by the National Park Service. Known as the *Secretary of the Interior's Standards for Rehabilitation*, they are used throughout the country by the majority of America's preservation boards and commissions as a basis for local design review guidelines and for projects utilizing federal funds or tax credits. The National Park Service originally published them in 1977 and revised them in 1990. They cover historic buildings of all materials, construction types, sizes, occupancy, and they encompass the exterior and the interior of historic buildings. The *Standards* also address landscapes and new construction. They and other useful information and guidance related to rehabilitation and other treatments for historic buildings also are available for public use at the office of the Joint City-County Planning Commission of Nelson County.

Design Review Process

Local historic designation requires design review for projects involving local historic districts and landmarks. The following projects require design review:

- Projects or activities requiring a zoning compliance permit, including but not limited to new construction, demolition, and relocation;
- Exterior alterations not requiring a zoning compliance permit, including but not limited to paint color changes, siding installation, and roof and window replacement;
- Site alterations or landscaping not requiring a zoning compliance permit, including but not limited to replacement of foundation plants on front and side elevations, clear cutting or removing all or the most of the mature vegetation from an undeveloped site, fencing installation, alteration of a site's natural grade by six inches or more from natural/historic grade, addition of two or more parking spaces, and addition, not replacement, of other impervious surface over 200 feet in size; and,
- Sign installation.

Prior to initiating any of the above-listed projects or activities, owners must follow the following steps for obtaining a Certificate of Appropriateness (COA):

Step #1: Pre-Application Conference

While not required, a pre-application conference with the Preservation Administrator is highly recommended and allows the Preservation Administrator and Applicant to meet and discuss the project, de-

sign guidelines, application process and submittal requirements, and approval processes.

Step #2: COA Application Submission

The Applicant must complete a Certificate of Appropriateness (COA) application and submit the application, required documentation, and applicable fees. A COA application and checklist, deadline and meeting schedules, and fee schedule is available at the Planning Commission office or online at www.ncpz.com.

Step #3: Staff Review

The Preservation Administrator will review the COA application and supporting documentation and prepare a staff report. A copy of the staff report, along with the COA application and supporting documentation, will be mailed to each HRB member and Applicant prior to the scheduled meeting.

Provisional Approval: During the staff review, the Preservation Administrator may grant provisional staff approval for projects not requiring a zoning compliance or sign permit. Provisional staff approval may be granted based on apparent compliance with the adopted design guidelines and regulations and subject to final HRB recommendation and City Council final approval. If provisional staff approval is given, Applicants still proceed with the activity at their own risk.

Step #4: HRB Review & Recommendation

For all projects, except demolition: Within 60 days from the date of COA application submission, the HRB will conduct a meeting to review the proposed project to determine compliance with the adopted design guidelines and will make a recommendation on the proposed project to the Bardstown City Council.

For demolition projects: Within 30 days from the date of the COA application submission for demolition, the HRB will conduct a public hearing to evaluate economic hardship and to review testimony and evidence on whether the structure proposed to be demolished can be put to reasonable beneficial use, and reasonable return for income-producing properties, without demolition. See Section 9 of this manual for guidelines on Economic Hardship.

Step #5: Bardstown City Council Action

For HRB recommendations of approval: If the HRB recommends approval of a COA application, then the Bardstown City Council will take final action on the application and issue a Certificate of Appropriateness (COA). If the Bardstown City Council votes to deny the COA, then the Applicant may appeal the decision to Nelson Circuit Court as set forth in KRS 100.347.

For HRB recommendations of disapproval: If the HRB recommends denial of a COA application, then the Bardstown City Council will take final action on the application. The Applicant may appeal the HRB's recommendation and request a public hearing by the Bardstown City Council. The City Council must hold the public hearing and take final action within 45 days of the appeal. If the Bardstown City Council votes to deny the COA, then the Applicant may appeal the decision to Nelson Circuit Court as set forth in KRS 100.347.

Step #6: COA Issuance

Upon final action by the Bardstown City Council, a COA will be issued, and the Applicant may obtain all other applicable permits for the proposed project.

Step #7: Inspection & Enforcement

During the proposed project, the Preservation Administrator will conduct inspections to determine compliance with the approved COA. If the Preservation Administrator determines that the project does not comply with the approved COA, the Preservation Administrator will take action as set forth in the enforcement section below.

If at any time during the project, the Applicant makes any changes or revisions to the proposed project, not approved by the COA, the Applicant must submit a request for the changes or revisions. The Preservation Administrator will determine whether the proposed changes or revisions require staff approval or full HRB and City Council consideration.

Enforcement

Work undertaken without a COA or contrary to the Certificate of Appropriateness is a violation of, and is subject to, penalties and enforcement set forth in the Zoning Regulations of All of Nelson County.

The HRB and Planning Commission staff monitors properties within historic overlay zoning districts for compliance and investigates complaints received from other agencies or citizens. If the staff finds a violation, then the following steps will be taken to reach compliance:

1. If work is initiated without a COA, a stop work order is issued.
2. A notice of violation (NOV) is mailed to the property owner. The NOV cites the violation and necessary actions and deadline for compliance.

If work continues without a COA and the owner fails to obtain a COA, then the Planning Commission will take action in Circuit Court to cause compliance.

SECTION 2

A BRIEF HISTORY OF BARDSTOWN



The courthouse (built circa 1787) and public square, shown circa 1863, were focal points for Bardstown's initial growth. (SLIDE: 3150, Clay Lancaster Slide Collection University of Kentucky)

Bardstown was founded in 1780. In 1789 the Bardstown Trustees ordered a resurvey of the city's original street plan and established the present one-half acre lot plan and the dimensions of its streets and alleys. Bardstown became an important commercial center in Kentucky in the early 19th century. Nelson County produced an abundance of agricultural products and in its early days Bardstown supported a prosperous merchant and business class. The quality of the city's craftsmen and the wealth of its citizens are reflected in buildings such as the Nelson County Jail, Talbott Tavern, Harrison-Smith House, and McLean House, all centered around the courthouse square. Commercial development dominated the area along North Third Street . a major thoroughfare leading to Louisville. Wealthy residents located their substantial Georgian and Federal homes north and south of this commercial section along North and South Third Street, Flaget Avenue, Stephen Foster Avenue, and Broadway Avenue. The town's early beginnings enabled it to rival Louisville and Lexington as a political, commercial, educational, and architectural center.

The Catholic church influenced Bardstown's development. Bardstown had the largest Catholic population among 18th century Trans-Appalachian settlements, making it a hospitable location for the establishment of many religious orders. In 1819, St. Joseph Proto-Cathedral (now St. Joseph Basilica) became the first cathedral built west of the Appalachian mountains, and today is listed individually on the National Register.

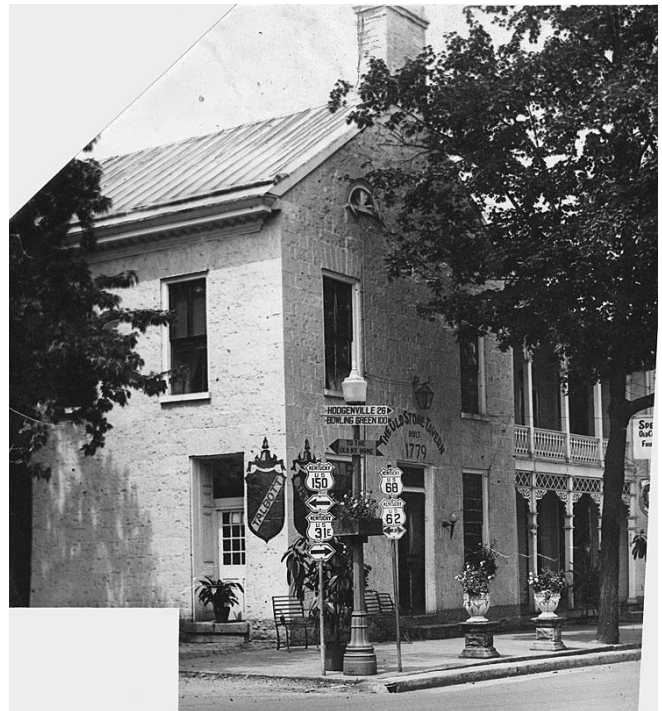

The Talbott Tavern, photographed circa 1930, remains an important Bardstown landmark. (Courtesy of Herald-Post Photographs Collection, Special Collections, University of Louisville)



Nehemiah Webb built this grist mill, formerly located on Town Creek and since demolished. (Courtesy of Dixie Hibbs)



Distilleries like Heaven Hill, photographed circa 1935, helped fuel Bardstown's late 19th and early 20th century growth. (Courtesy of the City of Bardstown)



St. Joseph's, photographed in 1933. (Courtesy of Herald-Post Photographs Collection, Special Collections, University of Louisville)

Social and physical changes occurring in late 19th century Bardstown changed its landscape again. Bourbon became an economic and cultural force in and around Bardstown. The trend began after the Civil War with the establishment of the Early Times and Jim Beam distilleries. By 1896, Bardstown boasted some 26 distilleries in operation in the area. This bourbon industry helped to foster Bardstown's residential and commercial development.



The current courthouse and many commercial buildings were built around the turn of the 20th century. This image shows Market Street (now East Stephen Foster Avenue) and the Courthouse circa 1920. (Courtesy of the Kentucky Historical Society)



St. John A. M. E. Zion Church (founded 1866), 219 East Brashear Avenue.



Street Scene - Bardstovn, KY.
This photograph looks south along North Third Street circa 1935. (NCPZ Digital Archive)

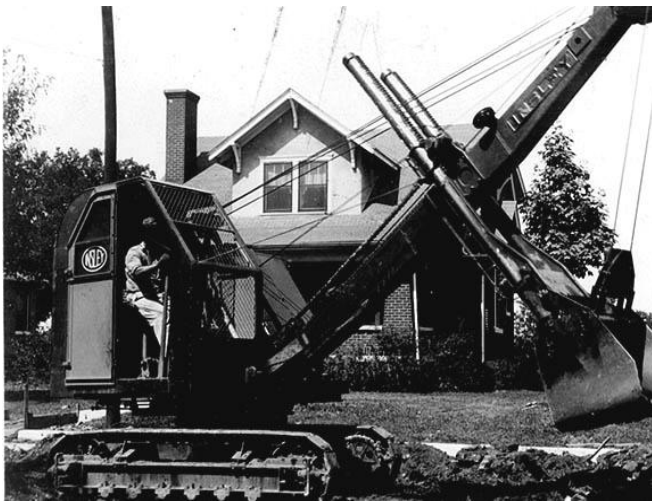

Early 20th century street paving and sidewalk construction on South Fifth Street. (SLIDE: 3150, Goodman-Paxton Photographic Collection University of Kentucky)

Modern Bardstovn has capitalized on its historic resources. The early adoption of historic overlay zoning in 1967, the listing of the district and individual listings in the National Register, and adoption of design guidelines in 1983 have all promoted preservation so successfully that heritage tourism, based on Bardstovn's historic character, is a major economic factor in the community.



This image of North Third Street, captured in 1923, shows the celebrations on the day that My Old Kentucky Home became a state historic shrine. (Courtesy of Jim Brooks)



Looking north along North Third Street in 1960. (Courtesy of the City of Bardstovn)

SECTION 3: ARCHITECTURAL STYLES

Architectural styles and building types present in Bardstown exemplify the town's development from its beginnings as a late 18th century settlement through its development into a 21st century tourist destination. Familiarity with historic styles and types should guide preservation and rehabilitation efforts, enabling residents to better maintain Bardstown's unique sense of place. The dates given for each style are approximate. In Bardstown, as in other places, builders and owners developed favorite styles which lasted longer than in other locations, and they often used elements from multiple styles on the same building.



Vernacular Houses: late 1700s - 1890

Vernacular houses are defined by their stock building forms and lack of stylistic detailing. Anglo builders in the 18th and 19th centuries usually constructed linear buildings that were one-room deep and this practice is reflected in the floor plans of Bardstown's earliest buildings. Before railroad transportation became widespread, vernacular builders relied on local materials and made ready use of the forests that covered much of eastern North America. Bardstown's earliest settlers, like those elsewhere in the region, constructed buildings of logs. Residents quickly established mills to process lumber, enabling the construction of new frame houses and the modernization of log houses through the addition of weatherboard siding. Bardstown's surviving early vernacular houses are important evidence of the town's initial development and the prosperity of many of its settlers. Changes in framing techniques enabled later vernacular houses to use massed plans, so called because of their two-room-deep floor plans. These later vernacular houses demonstrate the diversity of income and housing preference present in Bardstown around the turn of the 20th century. Typical floor plans of vernacular houses included: gable front (suited for urban lots), gable front and wing, hall and parlor, I House, massed side-gable, and pyramidal.

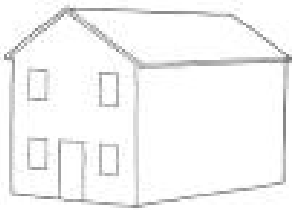

Gable-Front Plan



Gable-Front-and-Wing Plan

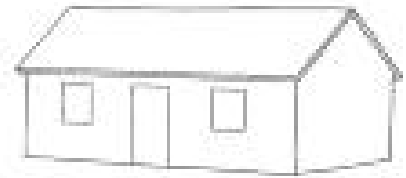

Hall-and-Parlor Plan

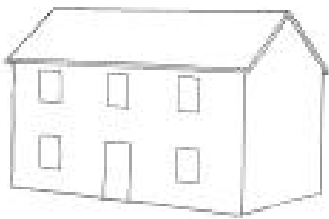

I-House Plan

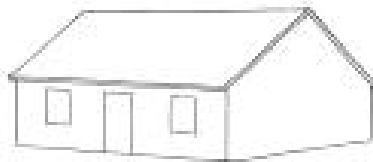

Massed Side-Gable Plan



Pyramidal Plan

Illustrations from *A Field Guide to American Houses*, by Virginia and Lee McAlester, 2006 edition.



The Yocum-Hite House at 201 East Stephen Foster Avenue was constructed circa 1792. The size of the dwelling indicates the high financial status of its initial owner.



At 512 North Third Street is a substantial front-gable and wing house. Its columns with Ionic capitals and cast-concrete piers represent limited Neoclassical and Craftsman influences.



The Rizer House at 208 North Fourth Street, constructed circa 1820, is two stories, proportionally balanced, and has a plain appearance. This house has a frame rear wing and weatherboard siding, with infill in the ell.



The house at 214 East John Fitch Avenue uses a one-story gable-front and wing plan. Its cornice with returns demonstrates Italianate or Greek Revival influences, and the porch, built in the early 20th century, is Craftsman style.



The Jacob Rizer House at 204 West Flaget Avenue was built circa 1802 and displays the center-hall plan with paired end chimneys.



This pyramidal house at 112 East Brashear Avenue has the square form and pyramidal roof popular in the early 20th century.

Federal: 1780- 1820

Federal architecture in Bardstown reflects the designs built by the city's upper class residents and mirrored national stylistic trends in the late 18th and early 19th centuries. Bardstown's remaining collection of Federal architecture signifies its prosperity and growth in the early 1800s. Facades are generally symmetrical and unadorned and entrances are the primary design features. Bardstown's Federal architecture favored brick construction and end chimney placement. The Federal style is also referred to as Adam style.

Typical Federal elements include: a semi-circular or elliptical fanlight over the door, entrances with or without sidelights, windows with double-hung sashes usually with six panes per sash and separated by thin muntins, and horizontally or vertically aligned windows in symmetrical rows.



The James Wright House at 204 East Broadway Avenue is a good example of a Federal row house. The sidelights and door surround indicate a transition from Federal to Greek Revival architecture.



Another Federal house is this one at 103 East Stephen Foster Avenue.



This duplex at 205 and 207 West Flaget Avenue combines an urban form with the Federal style.



The McLean House at 105 East Stephen Foster Avenue is an outstanding example of Federal period commercial architecture.

Greek Revival: 1825- 1860

Interest in classical western civilization peaked in the early 19th century. At the same time, the War of 1812 reduced the United States' interest in British architectural trends, including what one architectural history referred to as the "thoroughly British" Federal style. The Greek war for independence that followed further endeared things Greek to the newly independent United States. Greek Revival architecture became so popular in the United States that its mid 19th century contemporaries in this country often referred to it as the National Style.

Typical Greek Revival features include: a low-pitched gable or hip roof, a wide trim band along the cornice line, entry or full-width porches with square or rounded columns, and a front door surrounded by narrow sidelights and a rectangular transom.



The house at 312—314 North Third Street displays several elements of the Greek Revival style. (NCPZ Digital Archive)



Bardstown architect and builder Osso Stanley added this Greek Revival porch, with pediment, block modillions, and Doric columns, to Shadowlawn, a Federal style home built in 1825 by noted architect John Rogers.



The house at 402 North Third Street has many Greek Revival features, including a low pitched roof, a porch with prominent columns, a cornice line of the roof emphasized with a wide divided band of trim, and a front door surround.

Italianate: 1840- 1885

Romantic styles like Italianate reflected a building approach that valued emotion and decoration over the rationalism of the classically influenced styles that preceded them, and competed successfully with the earlier styles for popularity in the mid 19th century United States. Italianate architecture was widely popular throughout central and northern Kentucky both before and after the Civil War.

Typical Italianate elements include: a low-pitched roof, tall narrow windows, overhanging eaves with ornamental brackets, paired doors, and decorative lintels and hoods below and above windows and doors.



This Italianate style commercial building at 116 North Third Street has arched windows and hoods and a bracketed cornice.



The house at 501 North Third Street is a good example of Italianate residential architecture. (NCPZ Digital Archive)



This Italianate house at 211 East Flaget Avenue has overhanging eaves, cornices, brackets, and fascia boards.



This vertically oriented house at 415 North Third Street is Italianate in style. (NCPZ Digital Archive)

Queen Anne: 1880- 1910

The Queen Anne style was popular late in the 19th century. Pattern books helped to spread the style, which stressed asymmetry and decorated surfaces. It appealed largely due to its emphasis on domesticity and comfort. The availability of prefabricated architectural details helped also to popularize the Queen Anne style.

Typical Queen Anne features include: an asymmetrical façade, a front porch with ornamental woodwork, a steeply pitched irregularly shaped roof, and the use of texture and color to differentiate façade elements.



The house at 204 South Third Street has many Queen Anne elements including a tower, decorated gable field, porch, and various heights and projections of building bays.



The Queen Anne house at 108 West Broadway Avenue features variously shaped façade bays. (NCPZ Digital Archive)



The Queen Anne house at 112 South Third Street features Colonial Revival detailing.



At 217 West Flaget Avenue is a cross-gabled Queen Anne house. (NCPZ Digital Archive)

Folk Victorian houses combine decorative detailing similar to that used with Italianate or Queen Anne houses with the simple forms used by vernacular architecture. Railroad transportation networks and pre-cut detailing enabled owners of simple homes to decorate them with elaborate trim work for a dramatic appearance.

Typical features include: proportional and balanced facades, spindlework porch detailing, plain window surrounds, and smooth walls.



This vernacular gable-front-and-wing house (circa 1885) at 117 South Second Street has Folk Victorian stylistic details such as Steamboat Gothic trim, brackets, and cornice returns. (NCPZ Digital Archive)



This Folk Victorian house (circa 1900) at 202 West Flaget Avenue also has a gable-front-and-wing plan and has stylistic details including gingerbread trim, cornice returns, fish-scale shingles, and chimney pots. (NCPZ Digital Archive)

The Colonial Revival style looked backward for inspiration to architecture built in the earlier Georgian and Federal styles. Historians typically credit the centennial celebrations of 1876 with awakening a renewed interest in the early years of the United States. The earliest Colonial Revival architecture was typically somewhat grand in scale and designed by people who borrowed loosely from Colonial and early National precedents. Early in the 20th century, the fashion was to mimic these historic precedents as closely as possible. Finally, many Colonial Revival buildings became simplified versions of their stylistic predecessors that appealed to a broader range of residents.

Typical features include: a symmetrically balanced facade, pedimented entry porch, fanlight and sidelights around the door, multi-pane glazing in double-hung windows, and dentiled cornice.



This early Colonial Revival house at 502 North Third Street demonstrates Federal and Georgian influences in its pedimented dormers, arched windows, transom-and-sidelights opening surround, and Ionic capitals. The asymmetry created by its porches was influenced by the Queen Anne style.



This house at 206 East Flaget Avenue is characteristic of later Colonial Revival homes in its size, symmetry, and simple appearance.



The Dant House (circa 1910), at 211 South Third Street, is an example of a larger Colonial Revival house with its symmetry, accented entryway, double-hung multi-paned windows, and side-gabled form. (NCPZ Digital Archive)



The Old City Hall building at 207 North Third Street is an example of the Colonial Revival style and features a side-gabled roof, symmetry, and three-part window grouping.

Tudor: 1890- 1940

Tudor houses looked to Medieval England for precedent. In the style's early years, Tudor architecture tended to be designed by architects and closely mimicked late Medieval and Renaissance models. After World War I, the style evolved into a popular choice for modest, suburban homes and came to be defined by the external treatments, the steeply pitched front gables, and arched openings.

Typical Tudor features include: a steeply pitched roof with a prominent gable; half timbering; narrow grouped windows; and varied wall materials including decorative brickwork, stonework, and stucco.



This house at 201 South Third Street features a front-facing gable extended to one side with half timbering in the apex, wood shingles, and an asymmetrical façade.



A more modest example of the Tudor style is the Sears and Roebuck Cotswold cottage at 116 South Fifth Street.

Historians cite the 1893 World's Columbian Exposition in Chicago as a major influence in setting the Neoclassical style as a hugely fashionable one in the United States, though the style was not widely built in Bardstown. Like with other Classically influenced styles, symmetry was a dominant characteristic.

Typical Neoclassical features include: a full-height porch with classical columns having Ionic or Corinthian capitals, symmetrically balanced windows, and a center door.



This bank building at 101 North Third Street has a symmetrical façade, pilasters extending the height of the building, Ionic capitals, and a pediment over the entrance—all indicators of the Neoclassical style.

Craftsman: 1905- 1930

The Craftsman style emphasized the honest use of materials, horizontal forms, and use of wide eaves and ample porch space. This style dominated residential construction in the 1910s and 1920s in Bardstown and many blocks display excellent examples of this style. Bungalows, small low-to-the-ground homes with front porches and interconnected floor plans, were commonly built in the Craftsman style.

Typical features include: low-pitched gable roofs, exposed eaves with ornamental braces, porches with squared columns, horizontal emphasis, and natural materials such as wood or stone.



This Bungalow at 106 East Broadway Avenue has roof brackets, multi-light-over-single-light windows, and wood porch posts over flared piers.



The house at 202 East Flaget Avenue has Craftsman windows and porch features. (NCPZ Digital Archive)



The Craftsman house at 108 South Fifth Street combines the contrasting materials of brick and concrete.



American Foursquares, boxy turn-of-the-century houses like this one at 506 North Third Street, often used Craftsman features. (NCPZ Digital Archive)

SECTION 4

RESIDENTIAL DESIGN



Gunsmith Row, 200 block of North Fourth Street



201 West Flaget Avenue



217 West Flaget Avenue



215 East Flaget Avenue



312 North Second Street



117 West Broadway Avenue



216 East Flaget Avenue

(Photos from NCPZ Digital Archive)

ACCESSORY STRUCTURES

Historically, outbuildings were commonly constructed along with houses. They include smokehouses, dairies, stables, sheds, and garages.



317 Raspberry Alley

AC1 Retain historic outbuildings.

AC2 Repair historic outbuildings and their hardware using materials that match the original in size, style, color, and design.

AC3 If replacement is required, use replacements for historic materials and hardware that match the original.

AC4 New outbuildings and/or accessory structures should carefully use design, materials, scale, and placement in order to protect the district's historic character.

AC5 Pools, fountains, gazebos, and pergolas should be located so that they are not visible from the street.

AC6 New outbuildings and/or accessory structures must meet all applicable Zoning Regulations and be constructed in accordance with the guidelines for Residential New Construction.



This decorative brick beehive smokehouse at 114 South Third Street is one of the last surviving examples of its type in Bardstown.



Original garages should be preserved and maintained such as this one at 117 West Broadway Avenue.

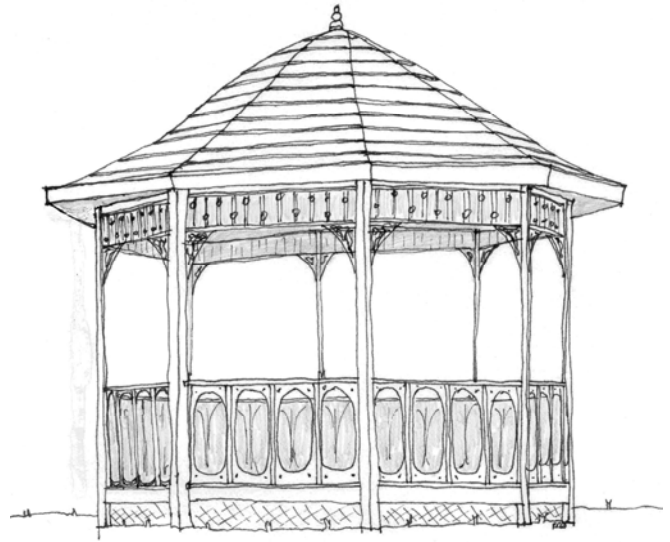

Gazebos in back yards are appropriate if not visible from public view.

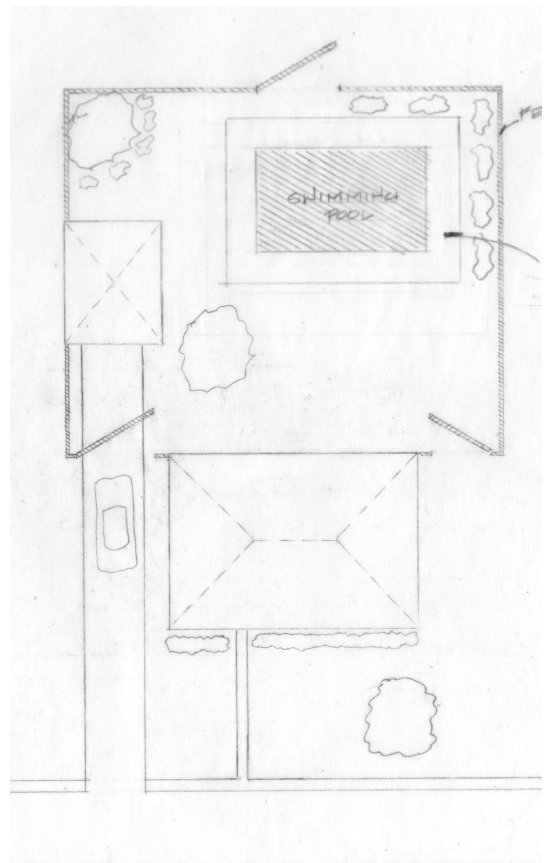

Landscape features like swimming pools should be located in back yards where not visible from the street. Plants and fencing may be used to help screen them from view.

ARCHITECTURAL DETAILS and FEATURES

Architectural details help determine building style, give clues about age, and contribute to historic character. They include features like trim work, bargeboards, brackets, dentils, cornices, shingles, columns, and pilasters.



501 North Third Street

- AR1** Retain historic architectural details.
- AR2** Repair historic architectural details with matching materials if they become damaged.
- AR3** Leave historic architectural details visible.
- AR4** Replace historic architectural details if they are missing or so badly damaged that replacement is necessary. Replacement elements should consist of matching materials, be the same size as the original elements, and be chosen based on physical or photographic evidence.
- AR5** Use wood epoxies to strengthen or reshape small rotted or deteriorated portions of wooden elements.
- AR6** Cut out larger deteriorated pieces of wooden elements and piece in wooden replacement pieces.

AR7 If replacement is required, replace wooden elements with new wooden elements.

AR8 Do not construct new features that are either falsely historical (characteristic of periods prior to the building's actual construction) or are incompatible with the building or historic district in terms of size, scale, material, or color.

AR9 Keep surfaces of metal and wooden architectural details painted as an important part of retention.

AR10 Photographically document architectural details that are slated for reconstruction or replacement prior to the removal of any historic fabric.

AR11 Use historical, pictorial, and physical documentation when undertaking the reconstruction of a missing feature. If there is not sufficient information to determine the original design, a new design should be prepared that is compatible with the architectural character of the building and the district. Conjectural or falsely historical designs are not appropriate.

AR12 Do not remove deteriorated metal features and replace them with elements that do not convey the same visual appearance. Do not remove such a feature and replace it at all.

AR13 Clean metal features only where such cleaning will not damage historic color, texture, or patina. Any cleaning treatment should use the gentlest means possible and first be tested in an inconspicuous location to determine potential adverse effects.

AR14 Use only those cleaning treatments that are appropriate to the type of metal being cleaned.

AR15 Clean soft metals, such as tin, lead, copper, terneplate, and zinc, using appropriate chemical methods, since blasting methods damage and pit their surfaces.

AR16 Clean hard metals, such as cast iron, wrought iron, and steel, with hand scraping or wire brushing to remove corrosion and paint build up. Low-pressure grit blasting may be used only if additional cleaning is required.

AR17 Do not expose metal types that require protection from the elements or apply paint or other coatings to metals that were historically meant to be exposed, such as copper, bronze, or stainless steel.

AR18 Reapply an appropriate paint or other coating system to previously painted metal features after cleaning. Failure to do so will result in accelerated corrosion of the metal or alloys.

AR19 Do not place incompatible metals together without a protective barrier since this can result in galvanic corrosion, such as copper corroding cast iron, steel, tin, or aluminum.



Cornices like this one at 203 South Third Street should be retained.



The brackets and window trim provide Italianate and Colonial Revival flourishes to the Queen Anne house at 112 South Third Street and should be retained as important parts of its varied stylistic character.



Brackets, gable returns, and window and door cornices all help define the mid 19th century Italianate style of the house at 211 East Flaget Avenue and must be retained to protect its integrity.



Wooden siding, doors, windows, trim, and other elements like those used at 204 West Flaget Avenue should be well maintained.

AWNINGS

Residential awnings were used during some historical periods to provide shade for windows and porches.



517 North Fourth Street

AW1 Use awnings only upon determination by physical or photographic evidence that they were originally included in the design of the residence.

AW2 Use awnings that are historically appropriate for the period and style of the residence.

AW3 Install awnings so that they do not interfere with the visibility of architectural details such as door and window trim, lintels, and surrounds.

CHIMNEYS

Chimneys are often prominent features on historic houses. As such, they are important to the historic Bardstown landscape and should be retained and repaired. If repair is not possible, they should be rebuilt with matching materials and mortar.



218 North Fourth Street



The chimney on the house at 117 West Broadway Avenue is an important feature and should be retained.

C1 Retain historic chimneys.

C2 Conduct repairs in kind to historic chimneys according to the masonry guidelines in this Manual.

C3 If chimney is damaged beyond repair, or missing, rebuild chimney to match the original, using matching materials and mortar.

C4 Use clay, slate, or stone for chimney caps, if needed. Metal chimney caps are not historically appropriate.

C5 If repointing an historic chimney is necessary, ensure that repointing does not change the original chimney size or shape.



The decorative appearance of chimneys like that at 205 South Third Street should be preserved through repair or replacement.

DECKS

Decks are modern features. Inconspicuous placement, design, and materials should be used to minimize their visual impact.



501 North Third Street

DE1 Locate decks on a rear or side elevation where they are not visible from the street.

DE2 Stain or paint decks to blend with or match the building.

DE3 Use a simple design and scale that is compatible with a building's historic features.

DE4 Use balusters and railings that blend appropriately in size and shape with historic buildings.

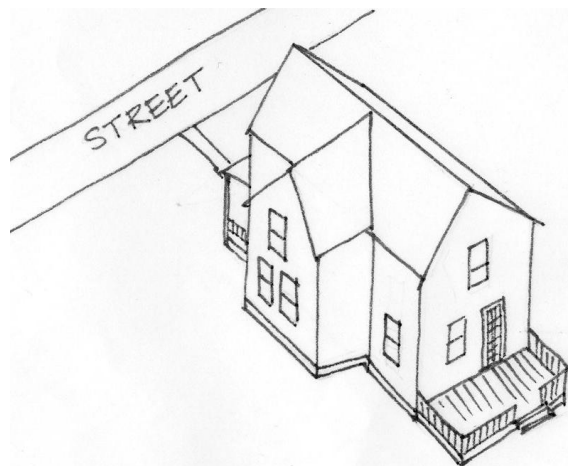

This deck is appropriately placed behind the house and out of view from the street.

DOORS

Doors and their surrounding entryways are central elements in a building's appearance. Historic doors and other elements should be retained, preserved, or repaired in kind. If repair is not possible, they should be replaced with one of matching style, size, and material.



113 East Broadway Avenue

DO1 Do not alter the character of entrances by either removing historic elements or through the addition of elements for which there is not historic precedent.

DO2 Retain and preserve historic doors, their surrounding entrance openings, and other surrounding elements such as transoms, sidelights, and pediments.

DO3 Photographically document doors or entrance features that are slated for reconstruction of replacement prior to the removal of any historic fabric.

DO4 Use historic, pictorial, or physical documentation when undertaking the reconstruction of a missing entrance feature. If there is not sufficient information to determine the original design, a new design should be prepared that is compatible with the architectural character of the building and the district. Conjectural or falsely historical designs are not appropriate.

DO5 Repair damaged historic doors or related elements using methods and materials that allow for the retention of as much original fabric as possible and that do not damage the original fabric.

DO6 Replace historic doors or related elements which are missing, or are so badly damaged that replacement is necessary, with those that match the original in style, size, and materials.

DO7 Use only those replacement doors that duplicate the design, proportion, and arrangement of paneling and glazing as the original.

DO8 Do not replace historic double-leaf doors with a single door.

DO9 Replacement of non-original, non-historic doors with new doors that are appropriate to the period and style of the building and are the size of the original opening is recommended.

DO10 Do not alter original openings to accommodate stock doors.

DO11 Differentiate between primary and secondary doors, using the detailing of the doors or the articulation of the frame.

DO12 Do not add vestibules to facades unless there is historic precedent. Such additions alter the character, proportion, and massing of the façade.

DO13 Do not create new entrances on elevations that can be seen from the street.

DO14 Retain historic screen doors and repair them using matching materials.

DO15 Install only screen doors or storm doors that are simple with a narrow-frame design and that are full view to enable the inner door to be seen.

DO16 If replacement is required, replace screen doors with wooden ones, in the same style as the house, with structural members aligned with the door.

DO17 Metal storm doors should be painted or finished to match the inner door. Dark baked-enamel or anodized frames are appropriate.

DO18 Retain historic security doors.

DO19 Use security doors that are full-view or plain design.

DO20 Install security bars only on rear or side elevations and in such a way that they do not obscure the architectural character of the original doors or damage historic fabric.



The door and surround of 202 South Third Street are appropriate models for Federal and some later 19th century house styles.



The entrance elements of the McLean House at 105 East Stephen Foster Avenue contribute to its historic character.



The replacement door on 318 North Second Street used appropriate design and materials.



The entrance at 212 East Stephen Foster Avenue contributes to the building's Federal style.



The paired paneled wooden doors at 211 East Flaget Avenue have a Classical-inspired surround.



Above are appropriate models for replacement doors on mid 19th century to early 20th century houses.



The house at 415 North Fourth Street has an Italianate surround.



Single-light glass-and-wood doors like these at 204 East John Fitch Avenue were widely used at the turn of the 20th century.



The storm door on 204 West Flaget Avenue uses appropriate materials and design.



Historic doors like the one at 210 East Flaget Avenue help define the historic character of buildings and neighborhoods.

HISTORIC PANEL AND GLASS CONFIGURATIONS SHOULD BE CONSIDERED

Inappropriate Replacements for Historic Doors

Replacement doors should have the same visual appearance as the original. Modern flush doors without paneling or with modern glazing configurations are not permitted. Six-panel doors are also not appropriate for most local preservation districts or landmarks.

(Courtesy of Metro Historic Landmarks Commission)

Door Parts

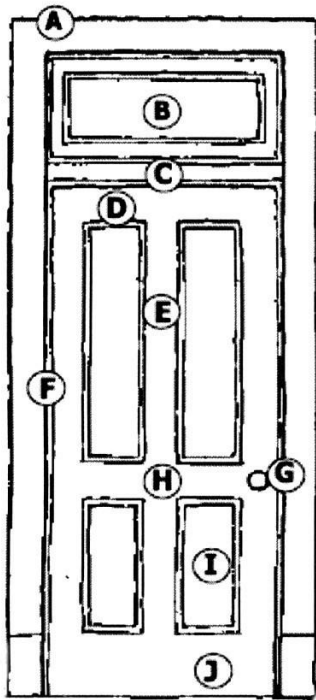

- A. Head Casing
- B. Transom
- C. Transom Bar
- D. Top Rail
- E. Cross Rail
- F. Hinge Stile
- G. Lock Stile
- H. Lock Rail
- I. Panel
- J. Bottom Rail

STORMS AND SCREENS SHOULD NOT CONCEAL

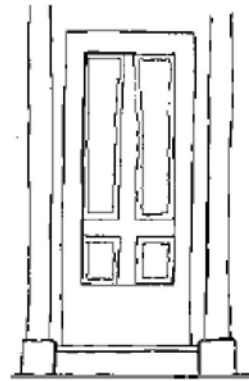

Appropriate

The historic door's appearance can be seen.

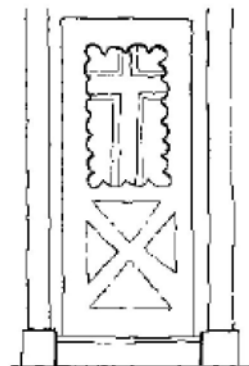

Inappropriate

The historic door's appearance is obscured.

If needed, storm doors and screen doors that have a narrow frame, which allow the door behind it to be seen, are preferred.

ENTRANCE TRIM MAINTAINS ARCHITECTURAL BALANCE—IT SHOULD NOT BE REMOVED

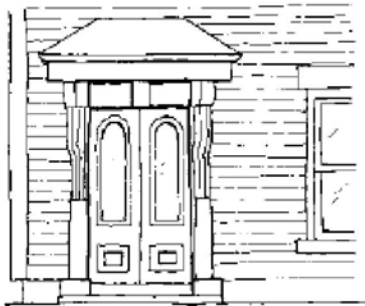

The original door surround frames the entry, giving it a feeling of substance and solidity.



Removal of the door surround disrupts the historic proportion of the entrance. The door appears to be ungrounded, "floating" within the facade.

REPLACEMENT DOORS MUST FIT ORIGINAL OPENINGS

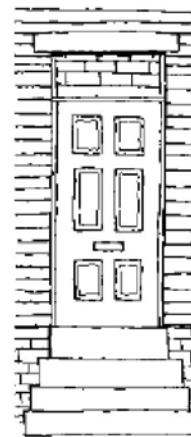

Inappropriate



Inappropriate

Blocking-in door openings to accommodate stock doors is not permitted.

All graphics on the page are courtesy of Metro Historic Landmarks Commission.

FENCES and WALLS

Fences are traditional ways of defining individual yards and separating public and private space. Walls often separate yard from sidewalks or divide yards internally. Historic fences and walls should be retained and repaired. New fences and walls should use historically appropriate designs and materials.



209 North Fourth Street

FE1 Consider the relationships that exist between the site and structure when making exterior alterations. Changes to one will affect the other. A primary goal should be to maintain a complementary relationship.

FE2 Retain historic fences and walls.

FE3 Repair historic fences and walls using matching materials.

FE4 Do not install front-yard fencing where there is no historic precedent.

FE5 Use historically appropriate fencing materials, such as metal for pre-1930 houses and wood.

FE6 Use materials that match existing sections of historic fencing in material, height, and detail when carrying out limited replacement projects. If an exact match cannot be made, a simplified design is appropriate.

FE7 Historically appropriate fence types for areas visible from the street include metal fences of simple design, wood picket fences, and plank fences.

FE8 Use substitute materials only if they match the site and building in materials and design and are not visible from the street.

FE9 Paint wood picket and plank fences white or beige or stained with a light color, and paint metal fences black.

FE10 Use privacy fences that are solid wood boards and that do not obstruct the historic view-cape from the street.

FE11 Solid wood board fences should have flat or arched tops.

FE12 Install any rear- or side-yard privacy fencing so that it presents the finished side out.

FE13 Do not install chain-link, split-rail, or wovenwood fencing, or concrete-block walls in areas that are visible from a public way. Opaque fencing, such as painted or stained pressure-treated wood, may be permitted with appropriate design.

FE14 Use materials that match the existing character of the original when replacing retaining walls or curbing. If an exact match can not be made, a simplified design is appropriate.

FE15 Do not install masonry walls in street-visible locations unless they are used to retain earth at changes in grade, screen service areas, or unless a historic precedent exists.



Historic cast iron fences like this one at 114 South Third Street should be retained and repaired.



The historic cast iron fence at 207 South Third Street is an appropriate model for new fencing with this pre-1930 house.



Solid wood fences, like the one at 204 South Third Street, may be used in side and back yards where not visible from the street.



The design, materials, and color of the wood picket fences at 113 East Brashear Avenue (left) and 317 Raspberry Alley (right) are appropriate.

FOUNDATIONS

Visible foundations are a typical feature of historic houses and can provide clues about how a house has evolved over time.



105 East Stephen Foster Avenue

- FO1** Retain historic foundations.
- FO2** Leave historic foundations visible.
- FO3** Conduct repairs and replacements to foundations according to the masonry guidelines.
- FO4** Use wooden lattice or boards for infilling by installing them between foundation piers.



The different foundations at 208 North Fourth Street demonstrate the house's evolution.



Repairs made to the stone foundation at 402 North Third Street should be in keeping with the masonry guidelines.



The carefully textured finish on the foundation stones at 502 North Third Street shows the house's turn of the century construction.

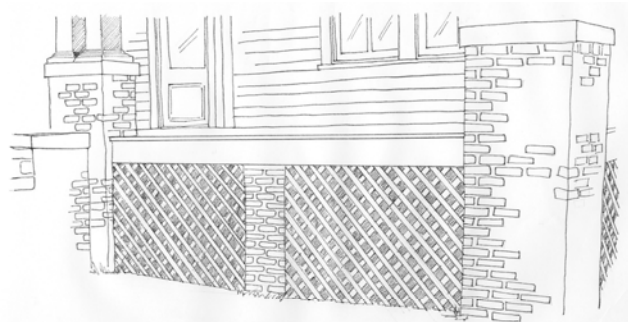

Wood lattice panels, placed between the piers, are appropriate to use for infilling.

GUTTERS and DOWNSPOUTS

Gutters and downspouts are important to building maintenance. They should be used and maintained.



105 East Stephen Foster Avenue

- G1** Retain historic built-in or boxed gutters.
- G2** Repair historic built-in or boxed gutters using matching materials.
- G3** Use replacement gutters that match the original in size, design, shape, and materials.
- G4** Do not destroy historic detail when installing replacement gutters. If synthetic materials are used, they should be painted to match the trim color.
- G5** Half-round replacement gutters that are of a simple design and do not alter the character of the trim, or in limited cases ogee profile gutters, are preferred. Synthetic materials painted to match the trim color are acceptable.
- G6** Do not use unpainted galvanized steel gutters or downspouts, which rust and stain adjacent materials. These gutters should be painted after a period of weathering. Vinyl gutters and downspouts should be avoided due to their short life expectancy.
- G7** Leave historically exposed rafter ends and eaves open and uncovered.
- G8** Use downspouts and splash blocks to direct water away from buildings.

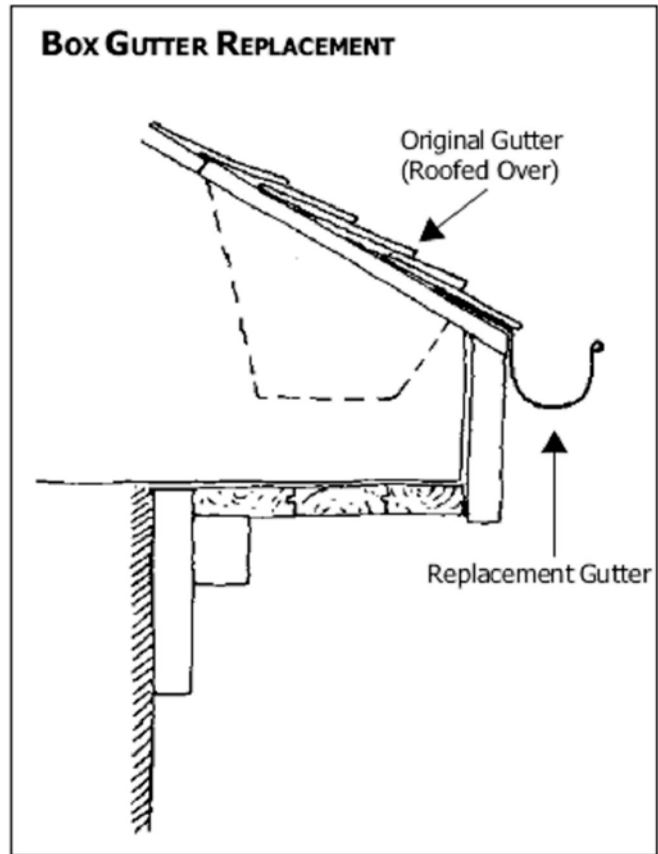

(Courtesy of Metro Historic Landmarks Commission)

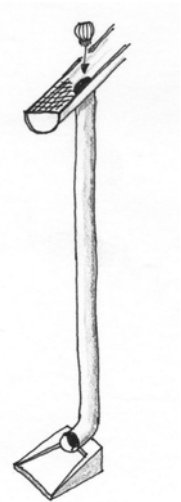

Downspouts and splash blocks can prevent damage to historic buildings.

LANDSCAPES

Landscapes should maintain continuity of appearance.



314 North Third Street (NCPZ Digital Archive)

LA1 Consider the relationships that exist between the site and structure when making exterior alterations. Changes to one will affect the other. A primary goal should be to maintain a complementary relationship.

LA2 Maintain original front yard topography, including grades, slopes, elevations, and earthen berms where present. New construction should match the grade of adjacent properties. Do not recontour front-yard berms into stepped terraces using railroad ties, landscape timbers, or any other historically inappropriate material for retaining walls.

LA3 Do not carry out excavations or regrading within or adjacent to a historic building, which could cause the foundation to shift or destroy significant archaeological resources.

LA4 Retain historic landscape features, such as the site's natural grade, foundation planting, natural vegetation, canopy trees, and historic viewscape.

LA5 Replace seasonal plants or vegetation so as not to obscure an historic building foundation.

LA6 Landscape alterations, including planting and sculptures, to the front and/or street-side elevations should be historically compatible in size, scale, and placement with the historic landscape patterns of the neighborhood.

LA7 Preserve large trees whenever possible and enhance established street tree patterns by planting additional trees along public rights of way. Consult the city arborist to determine what tree species are suitable for placement near overhead wires. Select and place street trees so that the plantings will not obscure historic features once mature. Removal of trees within or immediately adjacent to a public right of way or within public open spaces requires review unless directed by the city arborist for emergency or public safety reasons.

LA8 New trees should be planted to replace older trees that have been removed.

LA9 Take the health and shape of trees into account when pruning. Overpruning should be avoided.



The lawn grade and retaining wall at 114 West Beall Avenue are historic site features.



Trees are traditional landscape elements, as shown at 114 South Third Street. (NCPZ Digital Archive)

LIGHTING

Historic light fixtures should be repaired in kind or replaced if repair is not possible.



116 North Third Street

LI1 Retain historic light fixtures.

LI2 Repair historic light fixtures using materials that match the original in size, shape, and design

LI3 If replacement is required, replace historic lighting fixtures with those of similar design and materials.

LI4 New lighting fixtures should be made with historically appropriate materials and should be compatible in size, scale, and style with their placement on historic buildings and sites.

LI5 Use understated fixtures when installing any type of exterior lighting. Fixture attachment should be done so as not to damage historic fabric. Fixtures should not become a visual focal point.

LI6 Use low-scale lighting for walkways and patios.

LI7 Do not light parking areas, driveways, or architectural features in a harsh manner. An illumination level of .5 foot candles at the property line will be sufficient. Light should be directed down and away from neighboring properties.

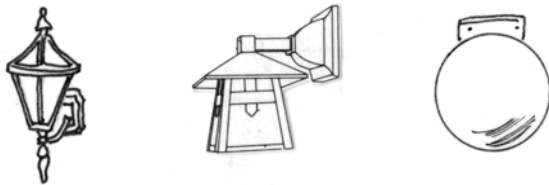

The simplicity and traditional design of the fixtures pictured are appropriate for new fixtures.

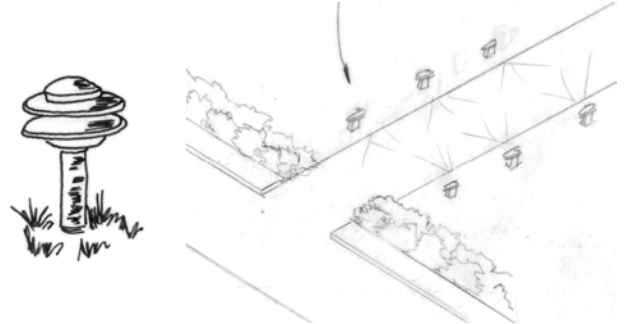

Landscape lighting, as shown above, might be appropriate to illuminate yard pathways.



Lighting placement on the porch roof at 206 East Flaget Avenue is appropriate.



The placement of the lighting fixture alongside the entryway at 209 East Flaget Avenue is appropriate.

MASONRY

Builders used bricks and stone to construct many of Bardstown's historic residences. These materials should be retained and repaired in kind.



116 Beall Street

M1 Do not construct new masonry features that are either falsely historical (characteristic of periods prior to the building's actual construction) or are incompatible with the building or historic district in terms of size, scale, material, or color.

M2 Do not cut new openings into exterior walls on elevations that can be seen from a public way. Creating an opening for the installation of an air conditioning unit, for example, is not appropriate for a façade that is visible from a public way.

M3 Photographically document architectural features that are slated for reconstruction prior to the removal of any historic fabric.

M4 Match the existing bonding pattern, coursing, color, size, strength, and pointing mortar of masonry when replacing a section of brick wall. Bricks should always be toothed-in to historic brickwork, to disguise the joint between new and old.

M5 Do not remove or rebuild substantial portions of exterior walls if such an action would adversely impact a structure's historic integrity.

M6 Make sure that any exterior replacement bricks are suited for exterior use.

M7 Do not replace sections of historic brick with brick that is substantially stronger.

M8 Repoint only those joints that are no longer sound. Do not remove all joints, sound and unsound, in an effort to achieve a uniform appearance when repointing. Large-scale removal of mortar joints often results in damage to historic masonry.

M9 Remove unsound mortar joints carefully with hand tools that are narrower than the mortar joint. Power tools should not be used, because they have the potential to scar adjacent masonry.

M10 Remove unsound mortar to a depth of two-and-a-half times the width of the joint or to sound mortar, whichever is greater.

M11 Match historic mortar joints in color, texture, joint size, and tooling when repointing.

M12 Use a mortar mix that is compatible with historic masonry. Repointing mortar should be equivalent to or softer than the original mortar. When repointing mortar is harder than the surrounding masonry, as is the case with many modern mixtures, moisture can not escape through the joints. Trapped moisture will crystallize within the walls and fragment surrounding brick and stone.

M13 If possible, have your mortar analyzed. In order to determine an appropriate mortar mix for individual historic structures, it is recommended that property owners have a sample of the original mortar sent to a lab for analysis. If this is not feasible, a high-lime and low-Portland-cement

content mortar mix (one part cement, one part lime, and six parts sand) if frequently acceptable.

M14 Do not attempt to remove joints that have been replaced using a very hard mortar or in an unworkmanlike manner until natural weathering has begun to weaken and crack them. Removal prior to that time would likely damage the masonry units.

M15 Do not use synthetic caulking compound to repoint historic masonry.

M16 Have realistic expectations of how the cleaned masonry surface will appear. Remember, it is better to underclean than overclean. A like new appearance is rarely desirable.

M17 Make sure that your contractor has a clear understanding of the physical and chemical properties of your masonry before proposing or testing any chemical treatments. Such treatments, if improperly applied, can result in permanent damage that significantly outweighs any benefits of cleaning.

M18 Test proposed cleaning treatments in an inconspicuous area of the building to evaluate potential adverse effects to the masonry. Observation over a complete seasonal cycle is preferable, so that long-term effects may be ascertained. If chemical treatments are found to be acceptable, be sure that those applying the treatments follow all manufacturers' instructions.

M19 Do not use sandblasting or high-pressure water to clean historic masonry. The process of sandblasting or cleaning buildings using water pressure greater than 300 psi removes the tough outer protective surface of the brick and loosens mortar joints, accelerating deterioration.

M20 Do not clean masonry on buildings with deteriorated mortar joints. Such masonry should be properly repointed prior to cleaning to ensure that water does not penetrate the wall during the cleaning process.

M21 Do not use any type of water- or chemical-based cleaning systems when a possibility for

freezing temperatures exists. Masonry cleaning should not be undertaken until the temperature will remain above 50 degrees for 72 hours after cleaning.

M22 Remove graffiti as soon as possible, beginning with the gentlest means possible and taking care not to inadvertently etch an outline of the graffiti onto the wall.

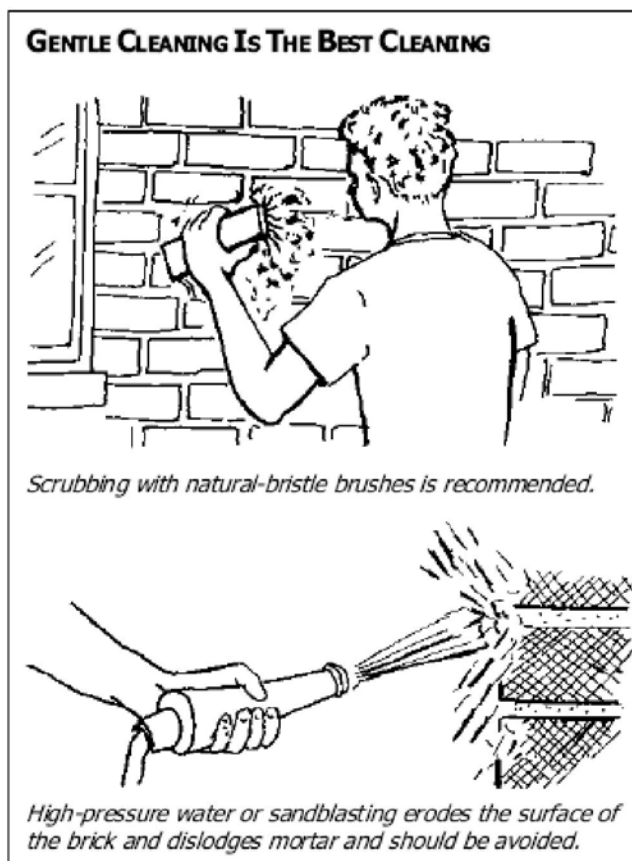

(Courtesy of Metro Historic Landmarks Commission)

M23 Use solvent-based chemical strippers to remove paint from previously painted masonry only after testing its effectiveness and evaluating its potential to damage brickwork. Testing should be carried out in an inconspicuous location.

M24 Do not paint masonry or stucco that has never been painted. While one layer of paint may not affect the appearance of the masonry or stucco, accumulated layers will eventually obscure decorative detail.

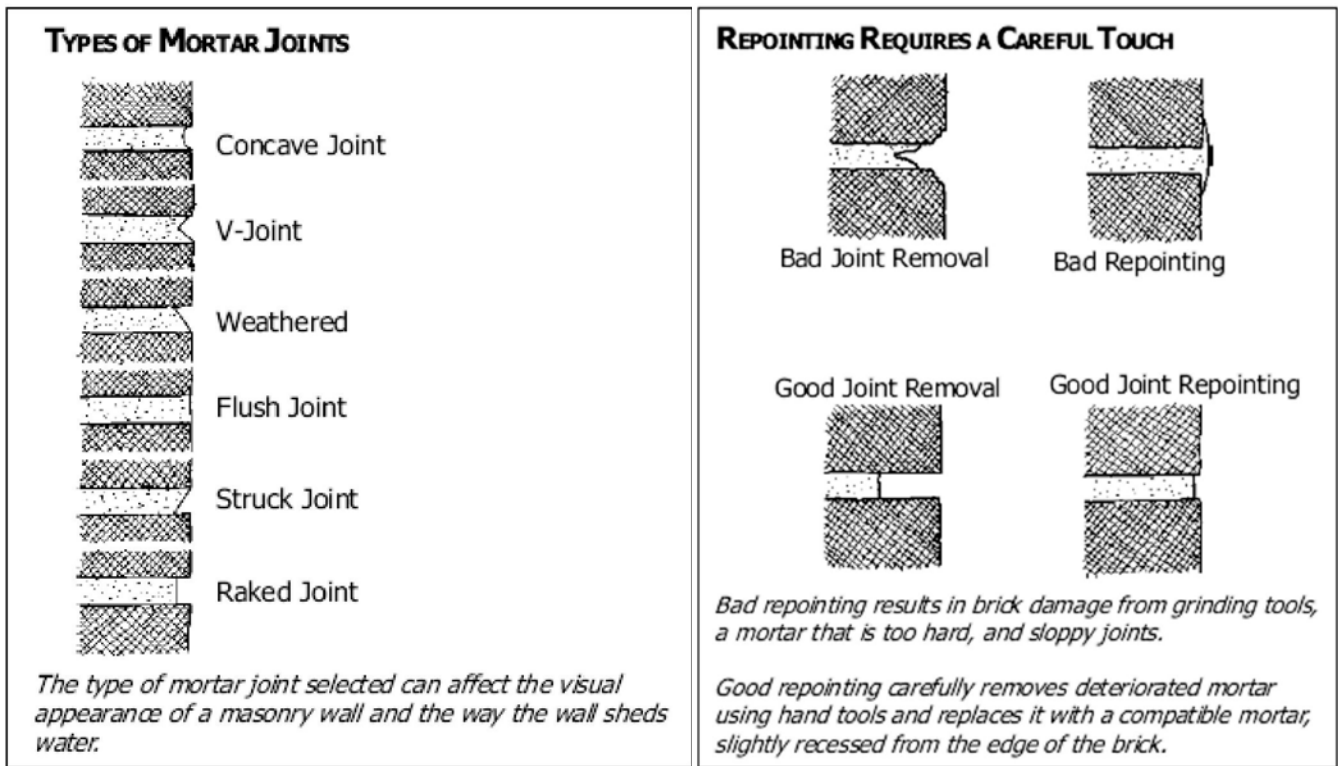

(Courtesy of Metro Historic Landmarks Commission)

- M25** Paint previously painted masonry a color that is close to its existing color, approximates a natural masonry color as approved, or is recommended by the staff. Staff is available to consult with you on colors.
- M26** Use a breathable masonry paint that is compatible with and can create a strong bond with existing paint.
- M27** Make sure that areas of patched stucco match the strength, composition, color, and texture of the original to the greatest degree possible.
- M28** When patching stucco, cut back the successive layers to provide a key for the new layers to prevent new cracking.
- M29** Carry out stucco repairs so that the dimension between the surface of the stucco and adjacent finishes remains unchanged.
- M30** Do not install stucco, Dryvit, or permastone-type cladding over historic masonry or wood siding.
- M31** Do not resurface historic masonry with exterior insulation.
- M32** Use a masonry or terra cotta chimney cap if needed. Metal chimney caps are not historically appropriate.

MECHANICAL EQUIPMENT, TRASH COLLECTION AREAS, and OUTDOOR STORAGE AREAS

Roof-top and ground-mounted equipment and trash collection and outdoor storage areas shall be screened from view using placement and/or appropriate materials.



207 West Broadway Avenue

ME1 Locate mechanical equipment and trash collection and outdoor storage areas behind buildings and completely screened from public view.

ME2 Screen equipment and trash collection and outdoor storage areas using landscaping, lattice panels, or similar materials that will form an opaque (solid) screen.

ME3 Locate mounted equipment, such as meters or window A/C units, on the rear or side elevations that are not visible to the public.

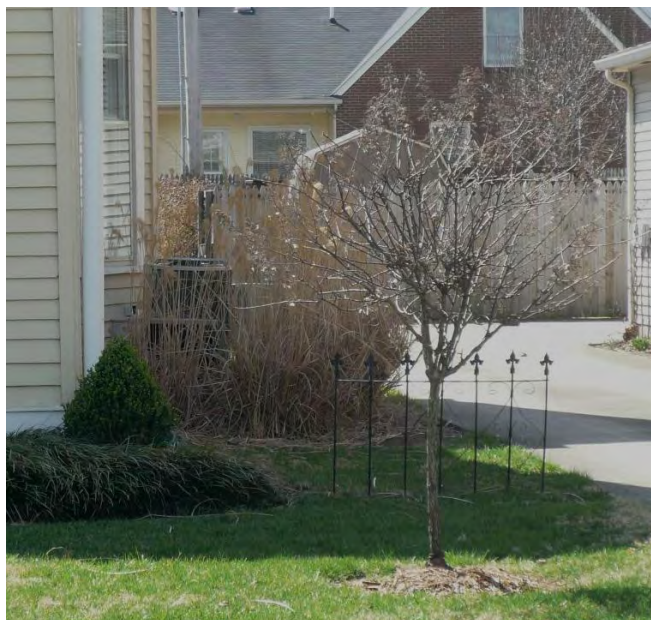

Plants and landscape elements help shield the air-conditioning unit at 213 West Broadway Avenue from view.



Placement behind the house hides the trash containers at 115 South Second Street from public view.

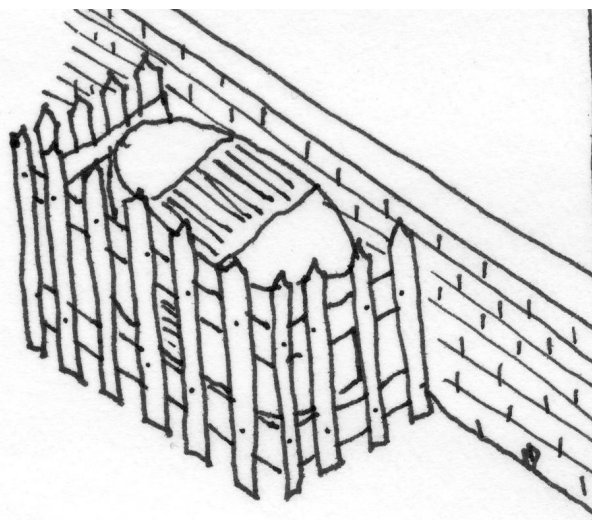

Lattice panels or fencing can help minimize the visual impact of mechanical equipment.

PAINT

Painting dramatically affects building appearance and maintenance; painting should both reflect owners' personal tastes and follow historic precedent in terms of placement and colors.



106 East Broadway Avenue

PA1 Painting masonry or stucco that has never been painted is not recommended. Paint is difficult to remove, accumulated layers will obscure decorative detail, and paint coatings (even breathable paints) will affect the wall's vapor transmission performance. The presence of a lead oxide wash does not constitute a precedent for painting a building.

PA2 Retain the painted finish of portions of the house's exterior that were traditionally painted, such as wood siding and trim.

PA3 Use high-quality primer and paint to provide a long-lasting finish.

PA4 Choose a paint scheme and colors that are compatible with the building's age and style. Changes to the color of exterior siding, trim, doors, windows, and shutters of buildings in the historic district require advance approval.

PA5 Paint should not be removed from wood by sandblasting or other abrasive methods.

PA6 Exterior surfaces of stained wood shingles should be retained as opposed to painted.

PA7 When removing paint from previously painted masonry, use gentle treatments that have

been previously tested in an inconspicuous location. Do not sandblast or use acid-based cleaners.

PA8 Use a breathable masonry paint that is compatible with and can create a strong bond with existing paint, only on previously painted masonry.

PA9 If painting previously painted masonry, select a color that matches the existing color, approximates a natural masonry color as approved, or is recommended by the staff. Staff is available to consult with you on appropriate colors.

WHERE PAINT REMOVAL IS REQUIRED, A GENTLE APPROACH IS BEST

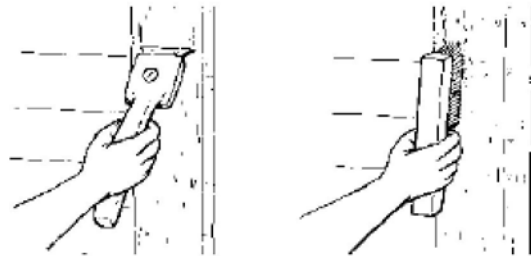

Handscraping and sanding is recommended for wood.

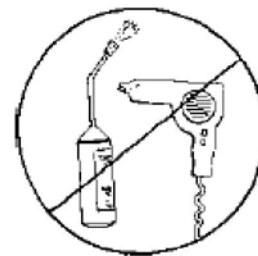

Hot-air guns and heat plates are not recommended for wood.

Test a chemical stripper in an inconspicuous area before applying it to masonry.

(Courtesy of Metro Historic Landmarks Commission)

PA10 Have paint samples analyzed when possible. Paint serratation studies can determine historic pigments and appropriate colors for repainting, by analyzing a paint sample under special light-

ing conditions to ascertain specific color, hue, and value of paint layers.

PA11 Do not expose metal types that require protection from the elements or apply paint or other coatings to metal that were historically meant to be exposed, such as copper, bronze, or stainless steel.

PA12 Paint replacement gutters, downspouts, metal-frame screen and storm doors and windows, roof-vent assemblies, and fire escapes to match wall, trim, cornice, or roof color of the house, whichever is most effective in reducing the visibility of these elements.

PA13 Be aware that historic structures often contain hazardous substances, such as lead paint and asbestos. Contact the Health Department regarding proper methods of removal and disposal.



Log houses, such as the Yocum-Hite House at 201 East Stephen Foster Avenue, should retain their unpainted body surfaces.



The Harrison-Smith House at 103 East Stephen Foster Avenue uses one of several typical Federal color schemes.



The Federal house at 110 East Broadway Avenue has a subdued color scheme and retains a painted finish on traditionally painted wooden elements. (NCPZ Digital Archive)



The brick body of the house at 116 East Stephen Foster Avenue should remain unpainted. (NCPZ Digital Archive)



The Italianate house at 415 North Third Street has an unpainted brick body. (NCPZ Digital Archive)



Queen Anne houses like this one at 204 South Third Street used color to highlight the varied surfaces that were so important to this style.



The brick body, concrete trim, and stucco surfaces of the house at 108 South Fifth Street should remain unpainted.

PORCHES, STEPS, and STAIRS

Porches were common features on historic houses. They served the practical function of providing a place to escape from the heat trapped inside the building in the summer and also served as places for relaxation and socialization.



109 South Third Street

PO1 Retain historically appropriate porches and their components, such as columns, posts, railings, balusters, molding, and trim.

PO2 Do not add porches to the facades of buildings that never had porches.

PO3 Repair damaged porch components with elements that match the original.

PO4 If replacement is required, replace damaged or missing porch components using materials that match the originals in size, shape, and style.

PO5 Photographically document architectural porch features that are slated for reconstruction prior to the removal of any historic fabric.

PO6 Do not enclose front porches and do retain the open nature of historically open

porches.

PO7 Screen porches using minimum amounts of wood or anodized or baked-enamel aluminum framing.

PO8 Screen panels that can be removed seasonally, are set behind porch elements, and do not damage historic fabric may be permitted.

PO9 Rebuild porches visible from the street using traditional materials: wood for 18th and 19th century porches and wood, brick, or concrete for 20th century porches. Rebuilt porches should match the original both in materials and in period style.

PO10 Design replacement porch railings and balusters to match the originals as closely as possible. If it is technically or economically unfeasible to accomplish this, a simplified porch rail and baluster design may be used by two inch by four inch rails and two inch by two inch pickets, set between top and bottom rails, and nailed to

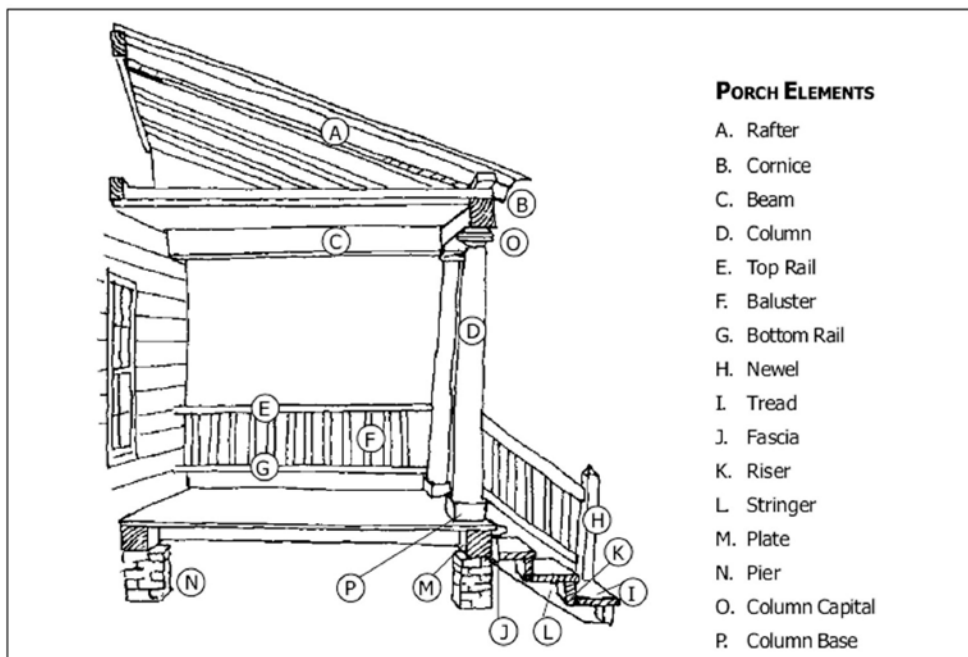

(Courtesy of Metro Historic Landmarks Commission)

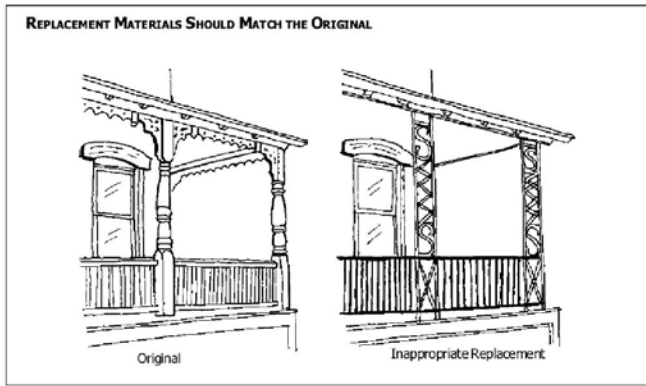

(Courtesy of Metro Historic Landmarks Commission)

the inside face of the rail. Railings should be finished with paint or an opaque stain.

PO11 Do not use cast or wrought-iron columns, railings, or balusters as a replacement for brick or wood porch elements. Columns should match the proportion, detailing, and size of the original.

PO12 When installing a new code-required handrail or railing, select a design that is simple and stylistically appropriate. Generally, metal is appropriate for masonry buildings and wood for frame buildings.

PO13 Do not add conjectural porch ornamentation; often its style conflicts with the style of the house.

PO14 Do not cover porch or cornice elements with vinyl or aluminum siding.

PO15 Rebuild deteriorated and unrepairable porch floors visible from the street using tongue-and-groove wood boards installed perpendicular to the house.

PO16 Do not use over-sized boards (two inches thick) for porch floors. Three-quarter inch to one inch tongue-and-groove boards are generally appropriate.

PO17 Install replacement porch flooring that closely matches the original tongue-and-groove flooring dimensions. A maximum gap of one-sixteenth of an inch should be left between boards to allow for expansion. Wood edging should be applied to the exposed ends of floorboards to prevent moisture infiltration into the grain.

PO18 Substitution of modern synthetic materials for wooden porch floors and other components will depend upon the visibility of the porch from the street or other public vantage point.

PO19 Do not install porch ceilings or close in exposed eaves where none existed previously. Exposed rafters and roof decks are character-defining features for certain architectural styles.

PO20 Use the same materials for a porch and its steps.

PO21 Replace deteriorated porch steps with in-kind materials. Replacement steps should be of the same scale and dimensions as the original. Stone steps may be patched with concrete that is tinted a visually compatible color.

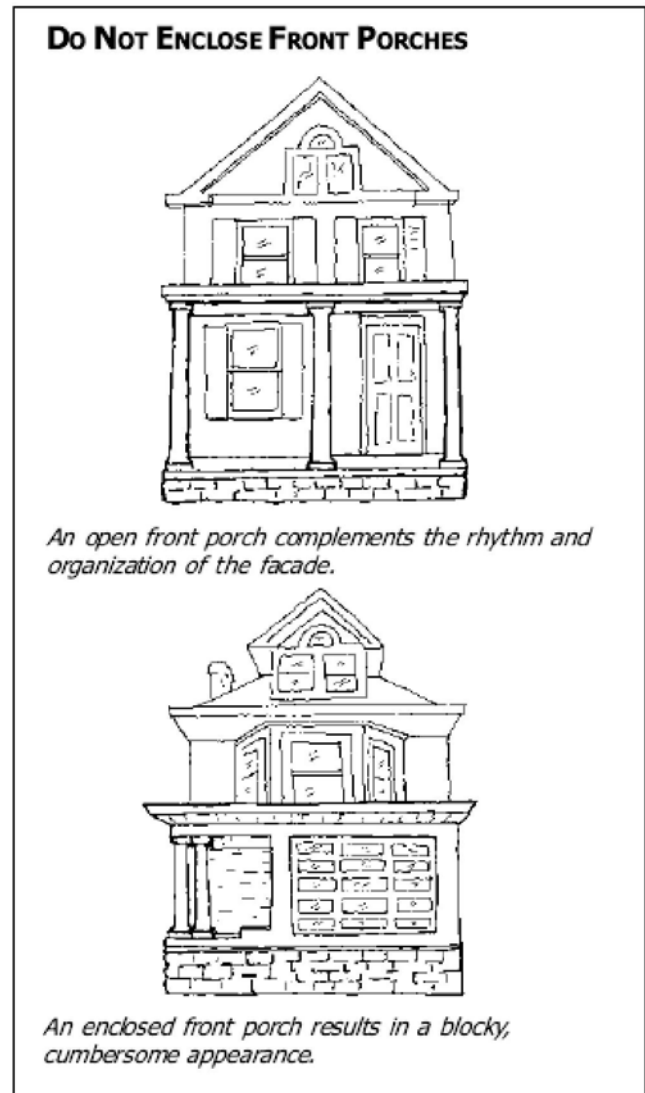

(Courtesy of Metro Historic Landmarks Commission)

PO22 Do not replace historic stone steps unless the stone itself is no longer usable. Resetting stones on a firm foundation and repointing or applying sealant can address most problems.

PO23 Do not obscure the design or detailing of original porch elements when undertaking a side or rear porch enclosure project. Large sheets of glass recessed behind original porch features should be used rather than solid materials such as wood, stucco, or masonry.

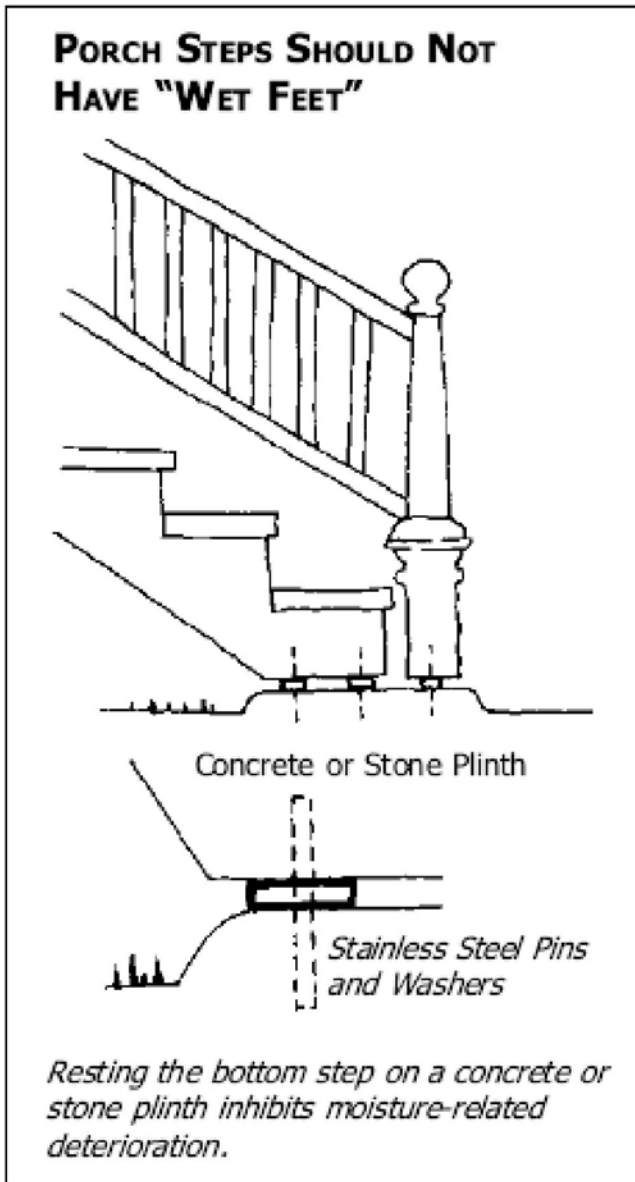

(Courtesy of Metro Historic Landmarks Commission)



The combination of materials on this porch at 216 East Flaget Avenue includes a cobblestone and concrete railing and paired Tuscan columns.



The column at 108 South Third Street and the distinctive post at 216 East John Fitch Avenue are character-defining elements.



The two-story Colonial Revival porch installed on the Federal house at 212 South Third Street demonstrates the house's historical evolution.



The historically open nature of this porch at 106 East Broadway Avenue should be retained.



If deterioration occurs on historic porches such as the one on 206 South Third Street, deteriorated areas should be removed and replaced.



The paired columns, simple Tuscan capitals, cornice returns, and size of the porch on 206 East Flaget Avenue are Colonial Revival elements.



Original steps like these at 103 East Stephen Foster Avenue should be retained.



Wood, like that used for the trim at 227 North Third Street, is a traditional material for porch elements.

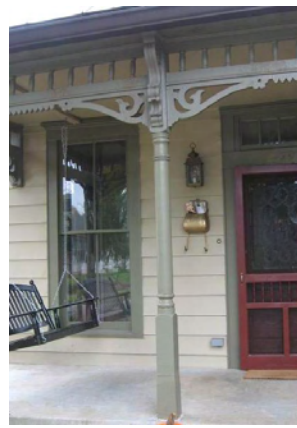

The milled posts and trim at 209 East Flaget are common on Romantic or Victorian houses.



Milled posts like these at 111 East Brashear Avenue are often available from wholesale companies.



The replacement porch on 201 South First Street used Neoclassical elements in its design.

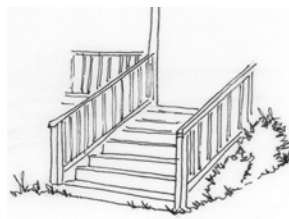

These simple railings are appropriate models for use with wooden porches.

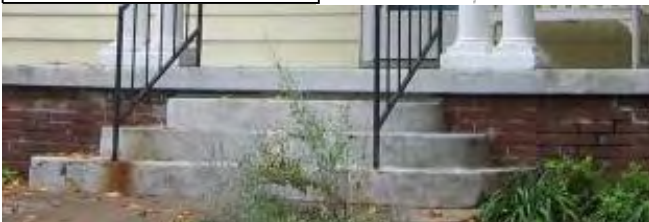
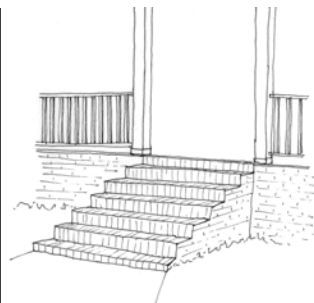
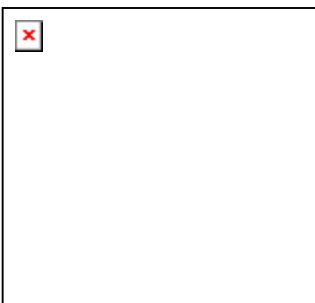

The wooden steps at the upper left, brick steps at the upper right, and concrete steps at 206 East Flaget Avenue all appropriately used materials that matched their porch's materials.



Craftsman posts like those at 210 East John Fitch Avenue can be ordered from milling companies.

ROOFING

Historic roof forms and materials should be retained and repaired.



213 East Flaget Avenue

R1 Retain historic roof shape, size, pitch, materials, and features, such as cresting, finials, and dormers.

R2 Use only replacement materials that closely match the original roofing materials in color, texture, and profile. Possible substitute materials include asphalt shingles, dimensional shingles, or cement tiles.

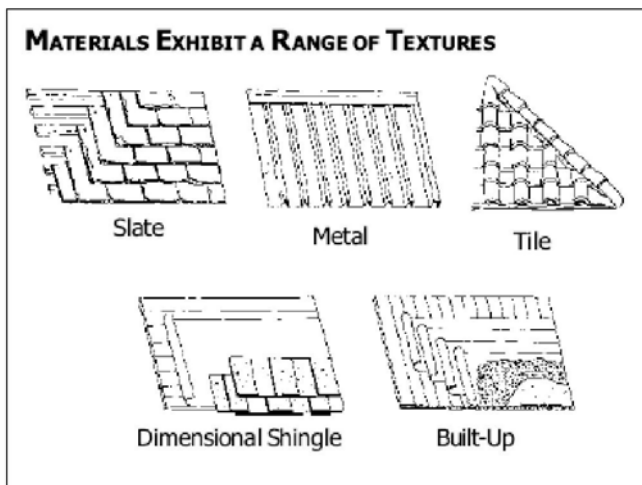

(Courtesy of Metro Historic Landmarks Commission)

R3 Use copper, lead-coated copper, terne-coated stainless steel, or terne metal when replacing a historic metal roof with in-kind materials. While copper roofs may be left unpainted, terne-metal roofs should be painted either muted

red or green, traditional roof colors. Replacement with in-kind materials is recommended in order to preserve the visual appearance of the original.

R4 Make sure that the proportion of the seams and trim on replacement metal roofing matches that of the original. Commercial-grade architectural metal roofing systems should not be used on residential architecture, because the scale is inappropriate.

R5 Retain ridge and hip tiles on historic tile roofs. Field tiles may be replaced with a compatible substitute material, such as a dimensional shingle in a color approximating the original. Ridge and hip tiles, however, should be reinstalled to maintain the roof's historic profile. Reinstallation of sound roof tiles and slates on smaller, secondary roof forms (porches, bay win-

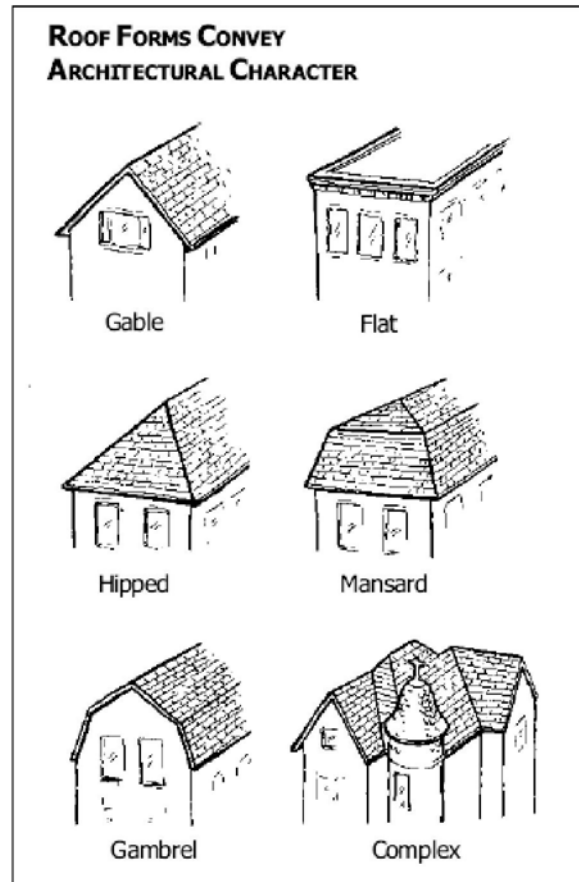

(Courtesy of Metro Historic Landmarks Commission)

dows, etc.) is encouraged whenever possible.

R6 Remove existing roofing material when replacing non-repairable or non-historic roofing. Removing these underlying layers will prolong the life of the roof and help restore the original profile of the roof edge.

R7 Do not apply asphalt shingles over wood shingles. This will trap moisture and cause deterioration of the roof structure.

R8 Base the reconstruction of any missing roof feature on historical, pictorial, and physical evidence. If such evidence is insufficient, the feature should be of a compatible new design rather than a falsely historical or conjectural reconstruction.

R9 New roof designs for additions or new construction should be compatible in size, scale, material, and color with the historic building and district.

R10 Use the form and detailing of severely deteriorated roof features, such as cupolas and dormers, or chimneys, to create appropriate replicas.

R11 Avoid having extensive areas of flashing visible. In some cases, portions of metal flashing may be covered by mortar or stucco.

R12 Do not destroy historic detail when installing replacement gutters. If synthetic materials are used, they should be painted to match the trim color.

R13 Leave historically exposed rafter ends and eaves open and uncovered.

R14 Make sure that any new roof-top additions do not compromise the structural integrity of the building and are screened from public view.

R15 Install any new roof-top mechanical or service equipment in such a way that historic fabric is not damaged.

R16 Do not attach antennae, satellite transmitters, skylights, vents, air conditioning units, decks, terraces, dormers, or solar panels that can be seen from the street. Skylights should be flush (not the bubble type) with curbs painted to match the color of the roof material. Consolidate antennae wherever possible.

R17 Do not introduce mechanical equipment or systems that may overload and compromise a historic building's existing structural system.

R18 Paint all roof vent assemblies to match the color of the roofing material.

R19 Do not install ridge vents on historic structures. They are non-historic approaches to attic ventilation.

R20 Replace historic roof details, such as decorative cresting and finials and metal ridge caps on slate roofs, with in-kind materials or materials that are visually compatible.

R21 Place skylights behind dormers, on rear slopes, or other locations not visible from the street.

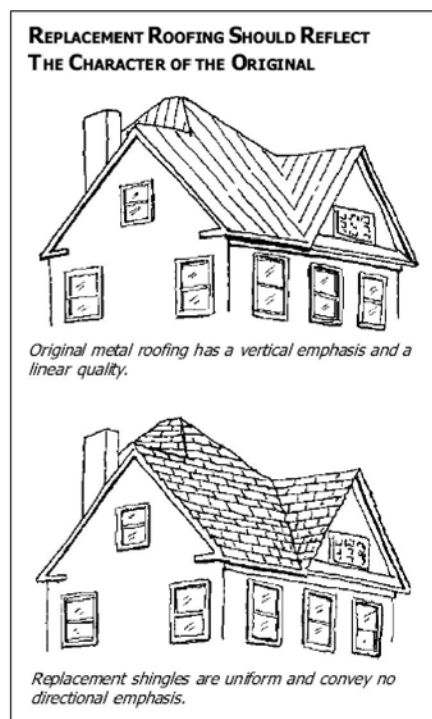

(Courtesy of Metro Historic Landmarks Commission)

DORMER ADDITIONS

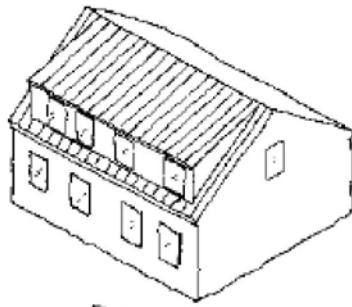

Too Large

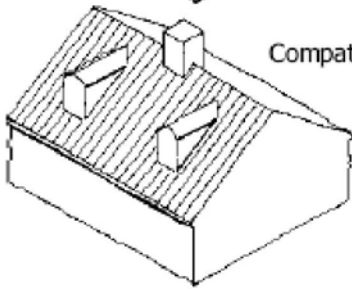

Compatible with Original

Keep dormers appropriately-scaled so that they do not overwhelm the historic roof form. Locate them on rear elevations where their visual impact is minimized.

(Courtesy of Metro Historic Landmarks Commission)

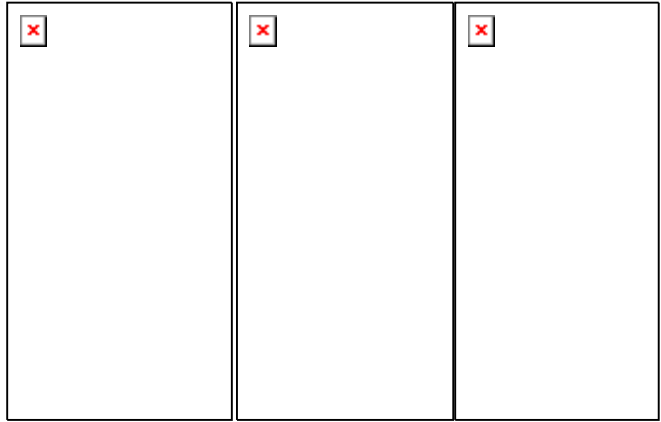

Placement and visibility from the street makes the skylights on the left two houses inappropriate. The ones on the right house are appropriate.

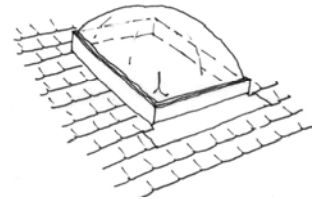
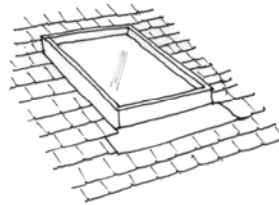

Using a flat skylight is more appropriate than convex forms.



Cresting and pressed-metal shingles add to the historic character of the house at 117 West Broadway Avenue.

SHUTTERS

Historic shutters should be retained, repaired, and, if repair is not possible, replaced with similar replacements.



511 North Third Street

SH1 Retain historic shutters and hardware.

SH2 Repair shutters with in-kind materials. If damage is so extensive that they can not be repaired, replacement shutters should match the visual appearance of the originals.

SH3 If replacement is required, replacements should be wooden, louvered (or of another style with historic precedent), and should cover the opening if closed. They should be mounted on window frames.

SH4 Install shutters only where there is historic evidence for them. Replacement shutters should be or appear to be operable, measure the full height and width of the windows, and be constructed of a historically appropriate material. Solid shutters are appropriate for the ground floor, and solid or louvered shutters are appropriate for upper floors.

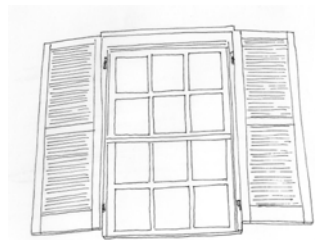

These appropriate shutters have proper style, fit, and mounting.

SH5 Mount replacement shutters so that they partially cover the vertical trim of the window frame. This gives shutters the appearance that they are indeed operable, even if in truth they are not. Shutters should not be applied to the masonry or cladding on either side of the window.

SH6 Do not install aluminum or vinyl shutters.

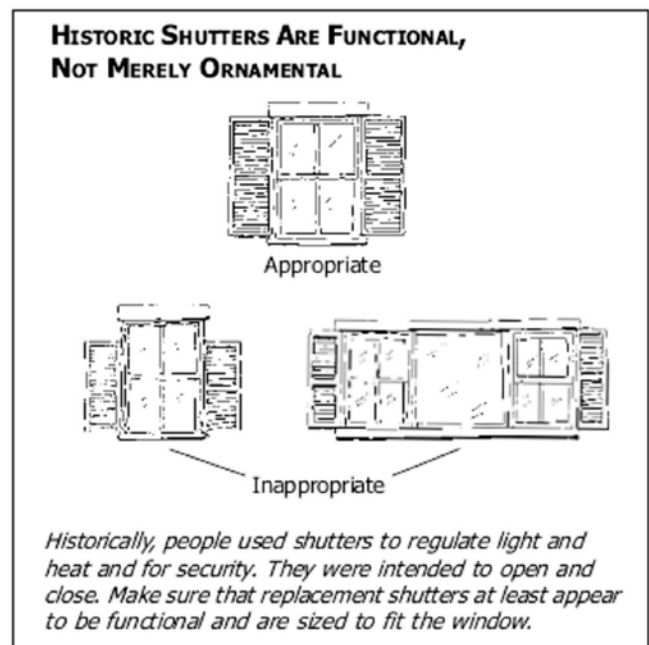

(Courtesy of Metro Historic Landmarks Commission)

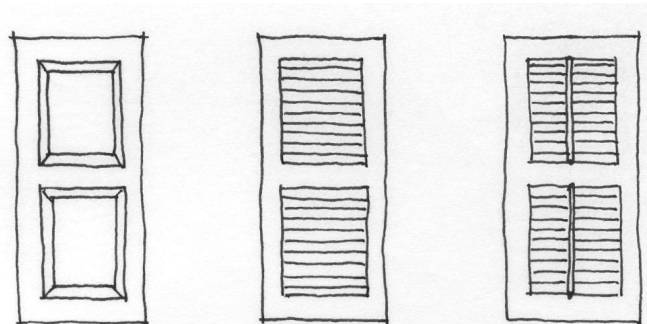

These paneled and louvered shutters are appropriate for doors and windows.

SIDING and TRIM

Siding is an important aspect of a building's appearance. Historic siding should be retained, visible, repaired, and, if repair is not possible, replaced with historically appropriate siding.



210 East Flaget Avenue

SI1 Retain historic siding.

SI2 Leave historic siding visible.

SI3 Repair historic siding using matching materials.

SI4 If replacement is required, replace historic siding with siding that matches the original.

SI5 It is preferable and acceptable to remove synthetic siding materials and to restore historic siding.

SI6 Do not replace missing wood features with conjectural or falsely historic reconstructions or with newly designed elements that are incompatible with the building's size, scale, material, or color.

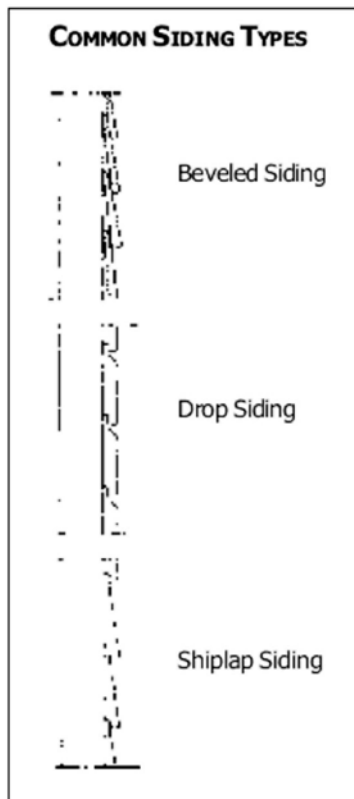

(Courtesy of Metro Historic Landmarks Commission)

SI7 Photographically document architectural features that are slated for reconstruction prior to the removal of any historic fabric.

SI8 Consider using contemporary wood siding, which conveys the visual appearance of historic siding, when replacement of such materials is required.

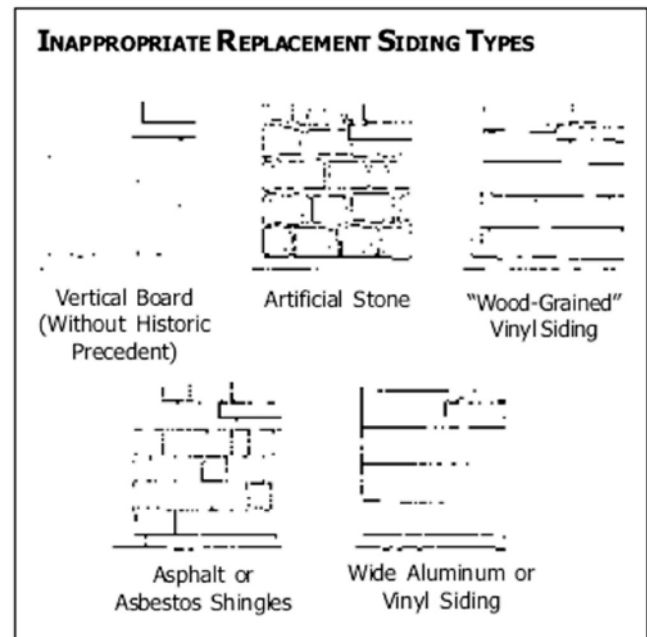

(Courtesy of Metro Historic Landmarks Commission)

SI9 Do not use textured plywood (T-111) vertical siding. It is not an appropriate substitute material.

SI10 Do not install artificial stone, asbestos shingles, or asphalt shingles over or as a replacement for exterior siding.

SI11 Orient all replacement siding horizontally, unless there is sound, historic documentation for a different original orientation.

SI12 Do not install vinyl or aluminum siding on primary elevations on historic buildings. Retention of exposed original wood siding is always preferred, however, if a decision is made to apply siding to side or rear elevations, it should be

done in such a way that does not obscure or damage historic ornamentation, such as fish-scale shingles, window casings, sills, hoods, brackets, and corner boards.

SI13 Use only vinyl or aluminum siding that matches the dimensions of the original siding. Generally, smooth-faced, narrow profile siding (three or four inches depending on the character of the existing siding) is acceptable for installation on secondary elevations. Wherever possible without causing damage to historic fabric, trim, such as corner boards, should project slightly beyond the vinyl siding.

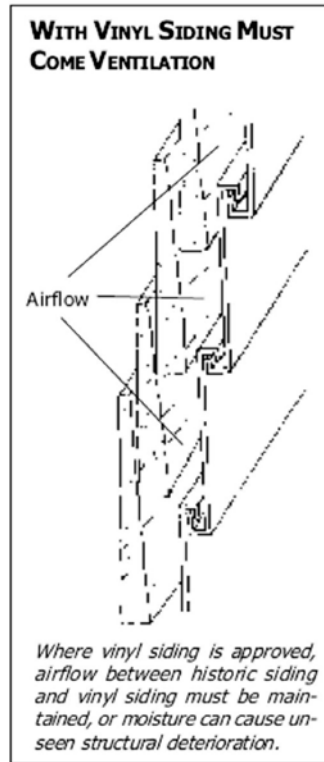

(Courtesy of Metro Historic Landmarks Commission)

SI14 Make sure that removal, handling, and disposal of lead-containing paint complies with all local, state, and federal standards.

SI15 Do not remove exterior siding to install insulation within the exterior walls of historic wood frame construction. This can result in damage to historic fabric. Installation of insulation with a proper vapor barrier should be done from the interior.

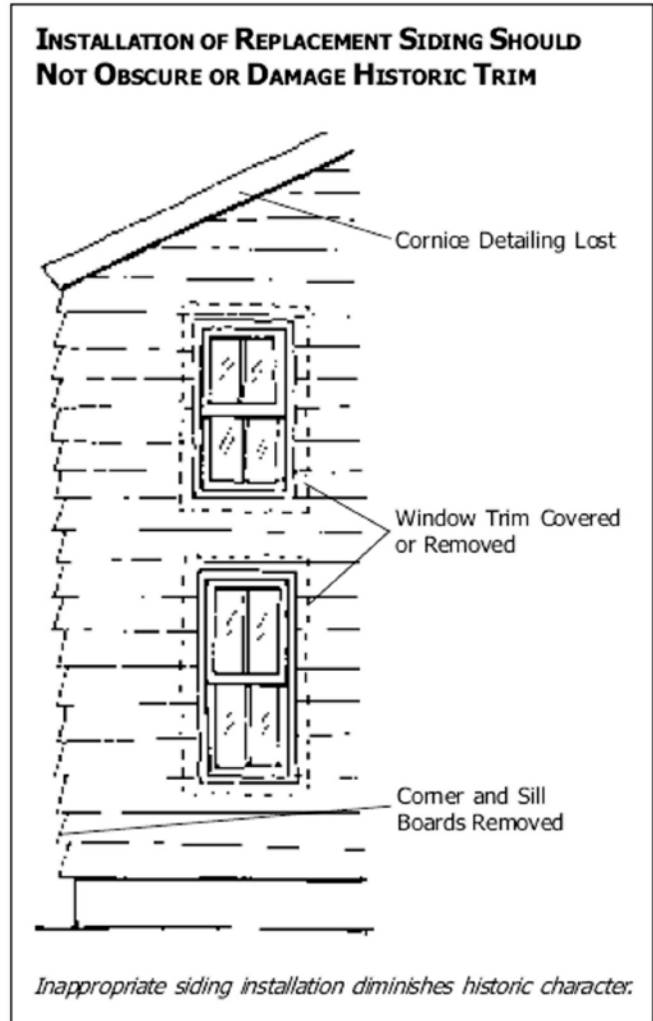

(Courtesy of Metro Historic Landmarks Commission)



Decorative siding materials like the hexagonal wooden shingles on 202 West Flaget Avenue should be retained and repaired.



This weatherboard siding at 208 North Fourth Street is almost 200 years old; its appearance adds greatly to the historic character of the property.

SIGNS

Signs in residential areas are limited to house or building identification signs, such as address or markers, and small identification signs for approved conditional uses. Historic signs should be retained and repaired.



107 East Broadway Avenue

SG1 Design signs to complement their surroundings. Signs should be integrated into the architectural design of the building and should not dominate the façade or interfere with adjacent buildings. Installation must comply with all other applicable city sign regulations.

SG2 Keep sign designs simple and easy to read. Use a limited number of lettering styles and colors, which reflect the character or the business and/or the building.

SG3 Attach signs on front walls or projecting from porches or eaves and near doorways or on porches, where such features exist, or in front yards.

SG4 All signs must comply with the Bardstown Sign Ordinance.



This standing sign is at 209 East Stephen Foster Avenue.

SITE

Elements of historic site plans, such as landscaping, paving materials, fencing, and public and private views, etc. are interrelated parts of historic properties and should be retained and restored.

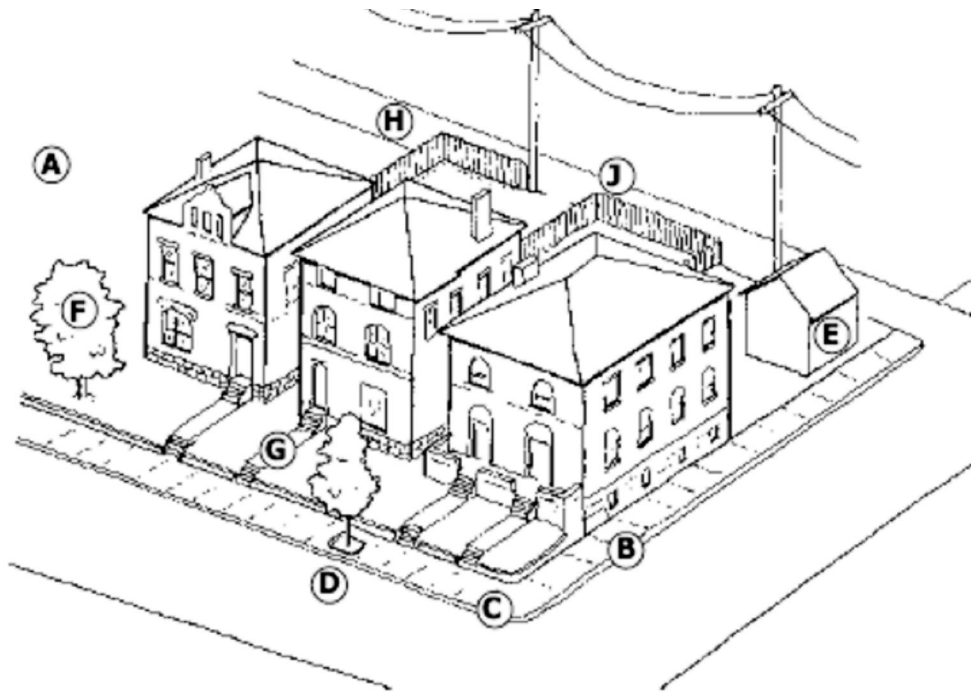

SITE CONSIDERATIONS

- | | |
|---------------------------|---------------------|
| A. Lot Size | G. Public Views |
| B. Building Setback | H. Private Views |
| C. Pedestrian Circulation | I. Street Furniture |
| D. Vehicular Circulation | J. Fencing |
| E. Parking | K. Lighting |
| F. Landscaping | |

(Courtesy of Metro Historic Landmarks Commission)

SE1 Consider the relationships that exist between the site and structure when making exterior alterations. Changes to one will affect the other. A primary goal should be to maintain a complementary relationship.

SE2 Retain established property line patterns and street and alley widths. Any replatting should be consistent with original development patterns.

SE3 Use paving materials that are compatible with adjacent sites and architectural character.

SE4 Restore and reuse historic paving materials for streets and sidewalks such as brick and hexagonal pavers and limestone curbing. Maintain original curbing whenever possible. The historic relationship between the road surface and edging should be preserved. Any replacement should use historic materials. If replacement with original materials is not technically or economically feasible, a substitute material may be used if it duplicates the color, texture, and visual appearance of the original.

SE5 Maintain brick, stone, or poured concrete wherever present. If replacement is required, original materials should be used. New construction should incorporate steps on blocks where they are a character defining feature.

SE6 Do not harm historic resources through road widening or underground utility repair.

SE7 Install utility lines underground.

SE8 Locate driveways and parking areas to the side and rear of properties. Access from alleys is preferred.

SE9 Maintain original front yard topography, including grades, slopes, elevations, and earthen berms where present. New construction should match the grade of adjacent properties. Do not recontour front-yard berms into stepped terraces, using railroad ties, landscape timbers, or any other historically inappropriate material for retaining walls.

SE10 Do not carry out excavations within or adjacent to a historic building, which could cause the foundation to shift or destroy significant archaeological resources.

SE11 Position fixtures, such as air conditioning units, satellite dishes, greenhouse additions, and overhead wiring, on secondary elevations where they do not detract from the character of the site. Try to minimize noise levels to adjacent properties.

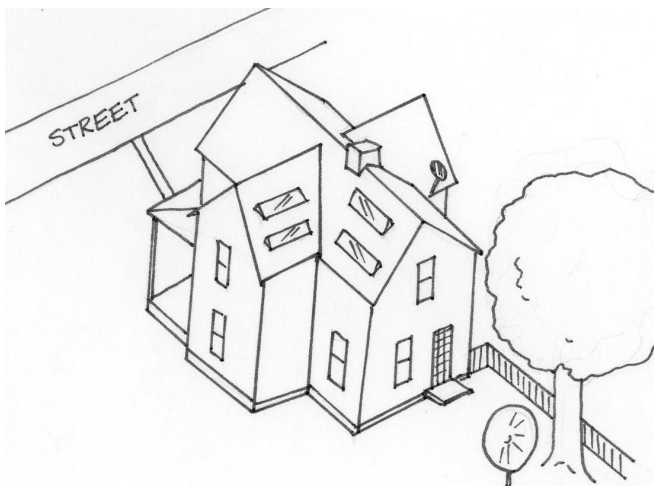

Placement of these solar panels and satellite dishes appropriately keeps them from street visibility.

SE12 Install any new roof-top mechanical or service equipment in such a way that historic fabric is not damaged.

SE13 Do not introduce mechanical equipment or systems that may overload and compromise a historic building's existing structural system.

SE14 Satellite dishes should be as small as possible.

SE15 If mounting solar panels or satellite dishes on the roof, place them on side or rear elevations with no street visibility.

SE16 If placing solar panels or satellite dishes in the yard, use side or rear yards with no street visibility. Screening with plants, fences, or other landscape features may be necessary.



The satellite dish at 108 East Broadway Avenue is toward the back of the side yard.

STREETSCAPE

Brick and concrete sidewalks and driveways are used in the residential and commercial sections of Bardstown's historic district. These materials should be regularly maintained and replaced with matching materials.



114 South Third Street

ST1 Retain historic sidewalks, driveways, and component elements.

ST2 Repair historic sidewalks, driveways, and component elements.

ST3 Maintain original curbing whenever possible. Any replacement should use historic materials. If replacement with original materials is not technically or economically feasible, a substitute material may be used if it duplicates the color, texture, and visual appearance of the original.

ST4 Restore and reuse historic paving materials, such as brick and hexagonal pavers and limestone curbing, whenever possible.

ST5 Retain historic circulation patterns, gateways, and entrances whenever they are character-defining features.

ST6 Construct driveways and component elements of historically used materials like concrete, bricks, or, for driveways, gravel or dirt. The use of asphalt for driveways is discouraged but acceptable.

ST7 Construct new sidewalks in historically appropriate locations, between the main front lawn and the narrow strip of lawn bordering the street and connecting the main sidewalk to the porch or entrance.

ST8 Construct new driveways in historically appropriate locations, alongside the house in the side yard.

ST9 Construct new concrete or brick driveways with either a solid surface or with two tracks.

ST10 Limit multi-car parking areas to locations out of public view and behind buildings or at the rear of building sides. If needed, solid

brick or stone walls or plants can help screen parking.

ST11 Do not carry out excavations adjacent to a historic building or site, which could cause the foundation to shift or destroy significant archaeological resources.

ST12 Use understated fixtures when installing any type of exterior lighting. Fixtures should not become a focal point.

ST13 Use high-pressure sodium or metal-halide lights to create a soft illumination where site or streetscape lighting is desired.

ST14 Retain trees to help define the streetscape unless they pose a safety hazard. Removal of trees within or immediately adjacent to a public right of way or within public open spaces requires review unless directed by the city arborist in cases of emergency or other reasons of public safety.

ST15 Preserve large trees whenever possible. Removal of trees within or immediately adjacent to a public right of way or within public open spaces requires review unless directed by the city arborist for emergency or public safety reasons.

ST16 Enhance established street tree patterns

by planting additional trees along public right of way and on private property. Select native deciduous species as canopy trees appropriate to the period and character of the district. Consult with the city forester to determine what tree species are suitable for placement near overhead wires. Select and place street trees so that the plantings will not obscure historic storefronts once mature.

ST17 Take the health and shape of trees into account when pruning. Overpruning should be avoided.

ST18 Install public utility lines underground.

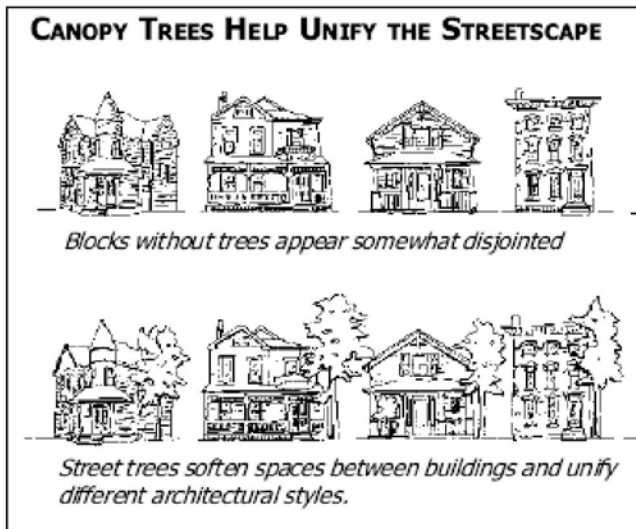

(Courtesy of Metro Historic Landmarks Commission)



The sidewalk, steps, and retaining wall at 208 East Flaget Avenue are historic elements.



Bricks like those used in the 200 block of West Flaget Avenue are the preferred materials for replacement sidewalks in much of the district.



In many residential district neighborhoods, the main sidewalk is located at the edge of the lawn and leaves a thin strip of lawn between it and the street, as shown above outside 214 East John Fitch Avenue.



In areas where street width eliminates yards as shown below along Stephen Foster Avenue, one or both sections of lawn may be eliminated.

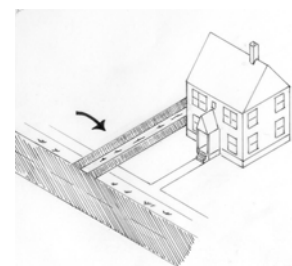

The design and placement of the driveway at 117 West Broadway Avenue and in the drawing are appropriate.

WINDOWS

Historic windows and openings contribute to the historic appearance and materials of houses. They should be retained, repaired, and, if replacement is required, replaced with similar windows. The addition of new windows is discouraged.



208 South Third Street

W1 Retain historic windows.

W2 Repair historic windows using materials that match the original.

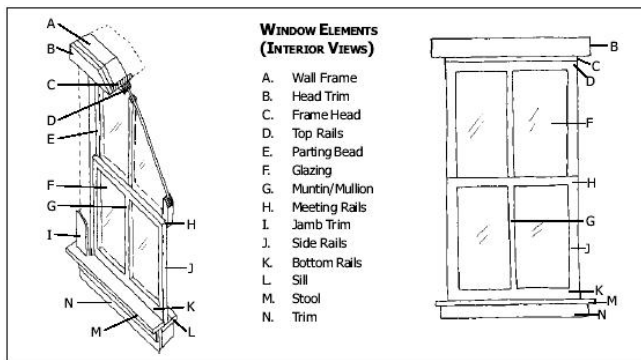

(Courtesy of Metro Historic Landmarks Commission)

W3 Replace severely deteriorated historic windows with new windows that convey the same visual appearance. Replacement windows may either be accurate reproductions using historical, pictorial, and physical documentation or be a new design that is compatible with the historic character of the building and the district. Use of vinyl and aluminum-clad wood window systems on

primary elevations may be permissible if the proportion and detail closely match the original.

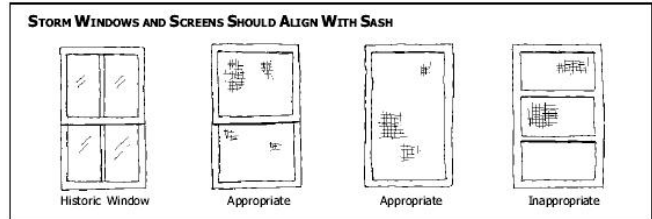

(Courtesy of Metro Historic Landmarks Commission)

W4 Select windows that match the historic sash dimension, muntin configuration, reveal depths, glass-to-frame ratios, glazing patterns, frame dimensions, trim profiles, and decorative features when repair of original windows is impossible.

W5 Evaluate the option of using appropriate salvage materials when replacing windows that are deteriorated beyond repair.

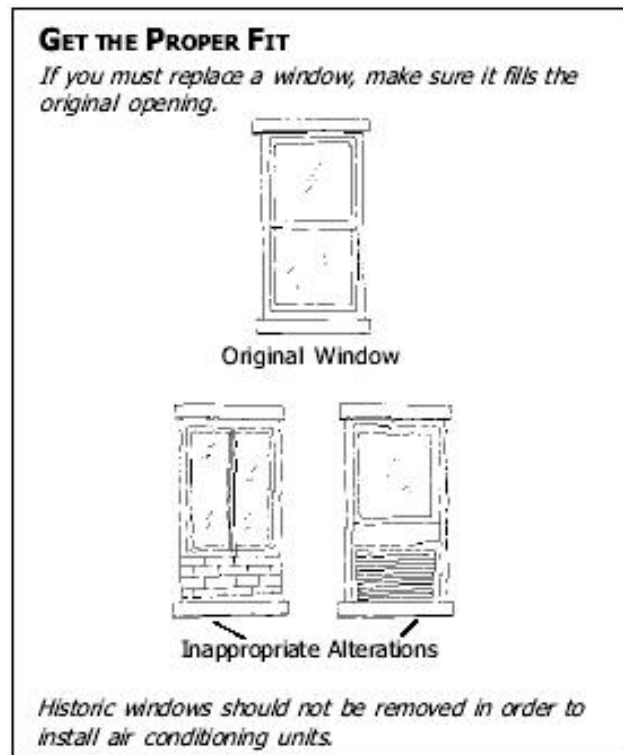

(Courtesy of Metro Historic Landmarks Commission)

W6 Do not use replacement sash that does not fit historic window openings. Original openings should never be blocked in to accommodate stock windows.

W7 Do not install contemporary picture, glass-block, or jalousie windows in exterior window openings.

W8 Do not install synthetic replacement windows (vinyl, etc.) on facades.

W9 Install replacement windows that operate in the same way as the original windows- double-hung windows are replaced with double-hung, and casement windows are replaced with casements.

W10 Do not replace multi-pane windows that have true divided lights with thermal-glazing windows that have false snap-in or applied muntins on primary façade elevations.

W11 Do not apply reflective or insulating film to window glass.

W12 Do not use smoked, tinted, or reflective glass on building facades that can be seen from a public way.

W13 Do not block in or back paint transoms or sidelights.

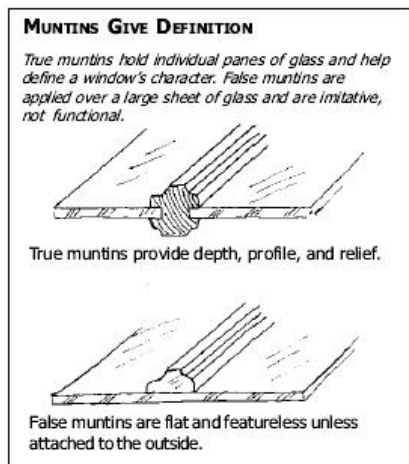

(Courtesy of Metro Historic Landmarks Commission)

W16 Locate any new windows openings that may be required for a new use on an elevation that cannot be seen from a public way. Newly installed windows should be compatible with the overall design of the building.

W17 Do not obscure historic window trim with metal or siding materials.

W18 Do not install new floors or dropped ceilings that block the glazed area of historic windows. If such an approach is required, the design should incorporate setbacks that allow the full height of the window to be seen unobstructed.

W19 Install exterior storm windows that duplicate the shape of the original window. Storm windows should be painted to match the color of the window frame.

W14 Use surviving prototypes to reconstruct missing window elements, such as architraves, hoodmolds, sash, sills, and interior or exterior shutters and blinds. The reconstructed element should be constructed of materials for which there is a historic precedent or a compatible substitute material if that is not possible.

W15 Do not alter the number, size, location, or shape of original windows seen from a public way by making new window openings or permanently blocking existing openings. If windows are no longer needed, they should be shuttered if original shutters exist. If shutters do not exist, a temporary closure should be prepared, leaving the window frame intact.

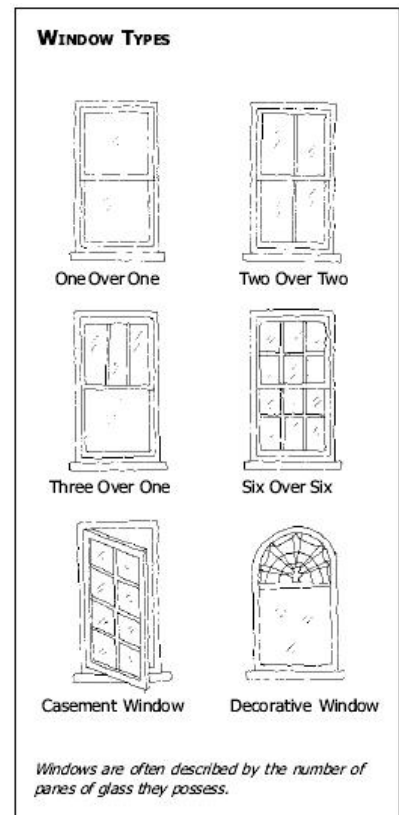

(Courtesy of Metro Historic Landmarks Commission)



(Courtesy of Metro Historic Landmarks Commission)

W20 Do not install exterior storm windows or screens that damage or obscure historic windows or frames. Mount storm windows on the blind stop within the window frame. Storm window or screen rails should always match the rails of the windows behind. They should have either wood or narrow, metal frames that are painted to match the color of the building trim.

W21 Do not install window air conditioning units on a facade if installation on a secondary elevation can address the same need. If this is not an option, do not alter the window sash to accommodate the air conditioning unit.

W22 Install any security bars in such a way that they do not obscure the architectural character of original windows or damage historic fabric.

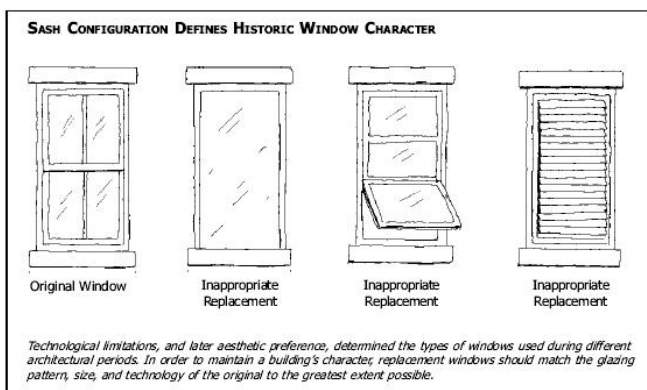

(Courtesy of Metro Historic Landmarks Commission)



The replacement window at 116 East Stephen Foster Avenue helps to retain the house's historic appearance.



The storm window on 211 East Flaget Avenue is appropriate.

Why Preserve Historic Wood Windows?

- Rebuilding historic wood windows and adding storm windows makes them as efficient as new vinyl windows and more than offsets the cost of installation.
- The old-growth lumber used in historic window frames can last indefinitely, unlike new-growth wood or vinyl.
- Vinyl window seals often fail after a few years, making their replacement more costly than upgrading historic wood windows.
- Vinyl windows don't look like historic wood windows; their texture and thinness are inappropriate for the historic district.
- Vinyl is harmful both in its creation and disposal.



Historic windows like these vertical sash Craftsman designs at 216 East John Fitch Avenue should be retained and repaired.



This Federal-style window at 216 East Stephen Foster Avenue is a defining feature of this house.

SECTION 5

RESIDENTIAL NEW CONSTRUCTION

New construction, including additions or new structures, must be suitable for the site and compatible with the adjoining properties and district. Additions should be in locations with no or very limited public visibility, have minimal effect on the buildings' form, appearance, and materials, and be both compatible and recognizably modern.

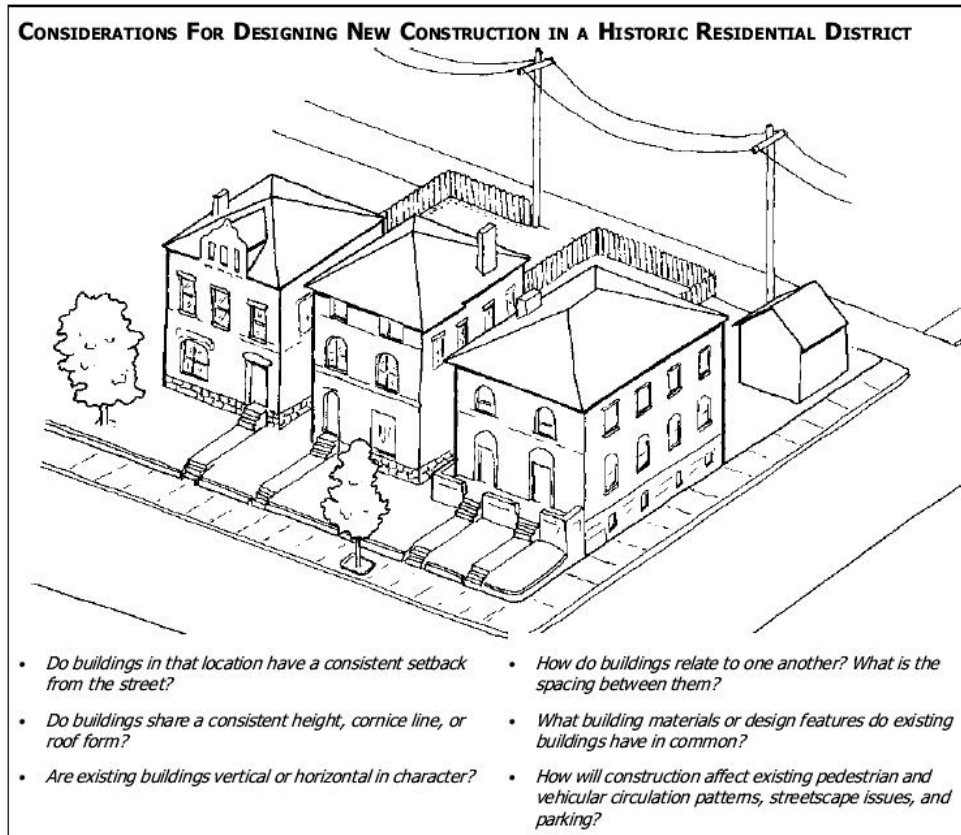

(Courtesy of Metro Historic Landmarks Commission)

NC1 Make sure that new designs conform to all other local regulations, including the Zoning Regulations, Building Code, and Bardstown Municipal Code.

NC2 Do not demolish structures in a historic district to make way for new construction, parking lots, or vacant lots. Non-contributing buildings are identified in each of the district or individual landmark designations or National Register Nominations.

NC3 Design new construction so that the building height, directional emphasis, scale, massing, and volume reflect the architectural context established by surrounding structures.

NC4 Make sure that the scale of new construction does not conflict with the historic character of the neighborhood.

NC5 Incorporate materials and design elements that complement the color, size, texture, and level of craftsmanship seen in surrounding buildings.

NC6 Do not use materials in new construction that are visually incompatible with surrounding historic buildings within the district. Materials to be avoided include: ornamental pierced concrete, masonry

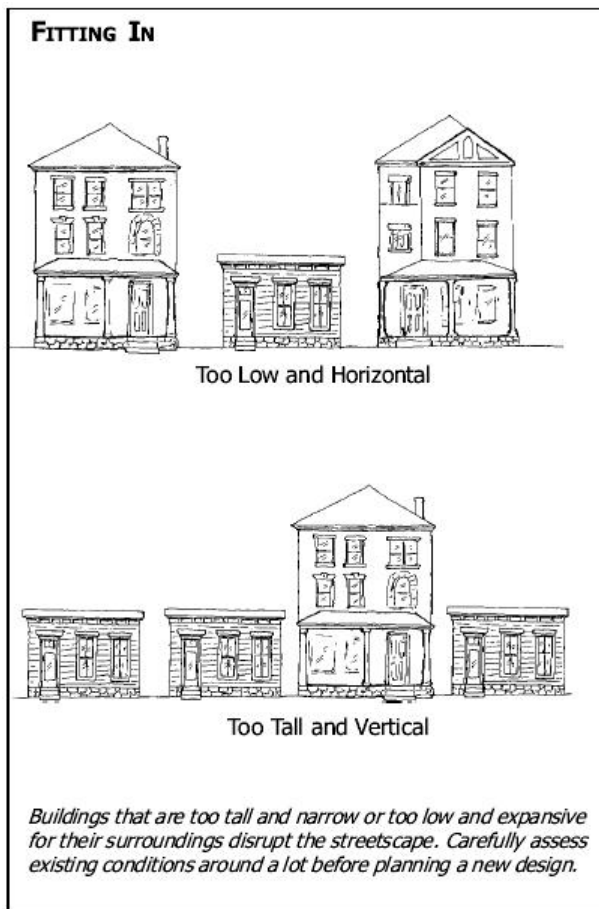

(Courtesy of Metro Historic Landmarks Commission)

screens and walls, antiqued brick, wrought-iron porch columns, chain-link fencing, exterior carpeting, jalousie windows, glass block, picture windows, unpainted wood, and asphalt siding.

NC7 Design new construction to reinforce the human scale of historic districts where this is a character-defining feature.

NC8 Design new construction in such a way that it does not disrupt important public views and vistas.

NC9 Reinforce existing patterns of open space and enclosure, created by circulation routes, fences, walls, lawns, and alleys of trees, in designs for new construction.

NC10 Design infill construction that reinforces the spatial organization established by surrounding buildings. The charac-

ter of historic streetscapes relies heavily on the visual continuity and patterns established by the repetition of similarly-designed facades.

NC11 Design infill construction in such a way that the façade organization closely relates to surrounding buildings. Window and door openings should be similar in size to their historic counterparts, as should the proportion of window to wall space. Cornice lines, columns, and storefronts are other important character-defining facade elements.

NC12 Design new construction so that the building mass has a similar sense of lightness or weight as surrounding historic structures. Mass is determined by the proportion of solid surfaces (walls) to voids (window and door openings). Historic window proportions are generally two-and-one-half (height) by one (width).

NC13 Develop designs for new construction using windows that are sympathetic to the window patterns of surrounding buildings. Use of comparable frame dimensions, proportions, and muntin configurations is encouraged.

NC14 Develop designs for new construction using front doors that are sympathetic to the door patterns of surrounding buildings. Use of comparable frame dimensions, proportion, and panel and lite configuration is encouraged.

NC15 Design new construction so that the orientation of the main entrance is the same as the majority of other buildings on the street.

NC16 Incorporate paved walks between sidewalks and the front entrances for new construction located on streets where this is a character-defining feature.

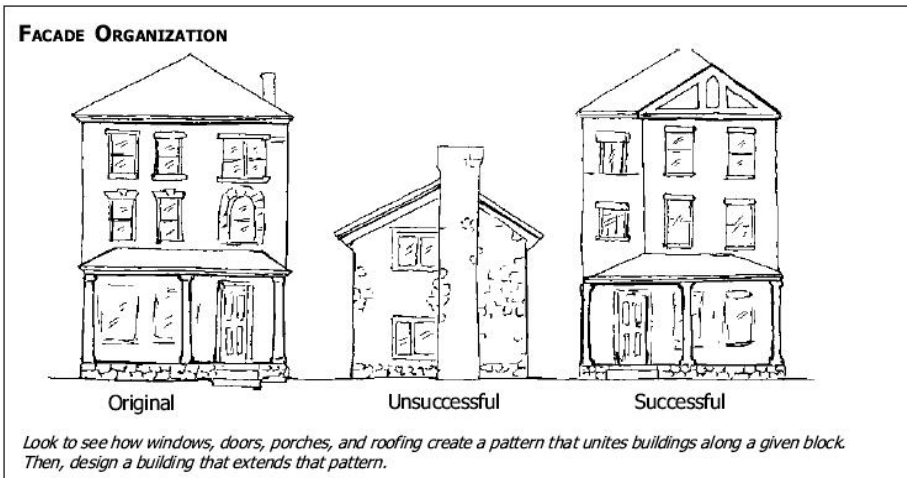

(Courtesy of Metro Historic Landmarks Commission)

NC17 Retain the character-defining features of a historic building when undertaking accessibility code-required work.

NC18 Investigate removable or portable ramps as options to providing barrier-free access.

NC19 Locate handicapped access ramps on secondary elevations whenever possible. If locating a ramp on the façade is required, it should be installed in a manner that does not damage historic fabric and is as unobtrusive as possible.

NC20 Design infill construction so that it is compatible with the average height and width of surrounding buildings.

NC21 Design new construction to have a floor-to-floor height that is within 10 percent of adjacent historic construction where the floor-to-floor height is relatively consistent, and a character-defining feature.

LINE UP—SETBACKS ESTABLISH BLOCK CONTINUITY

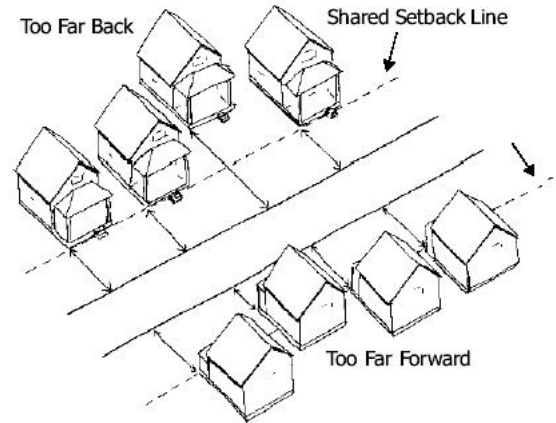

(Courtesy of Metro Historic Landmarks Commission)

GARAGE PLACEMENT

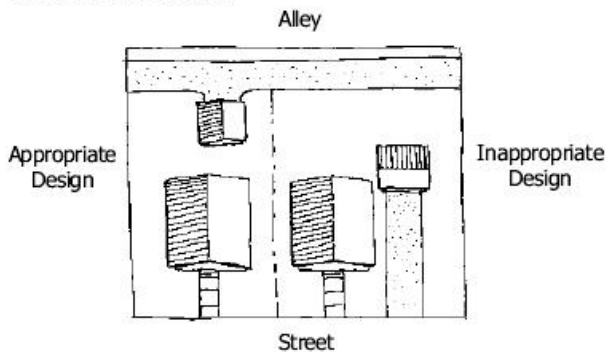

Garage access should be off alleys where they exist. Garages should also be positioned behind the main building to screen it from view. Keeping the roof line parallel to that of the main house or the prevailing roof line along the alley is best.

Appropriate Design Where No Alley Exists

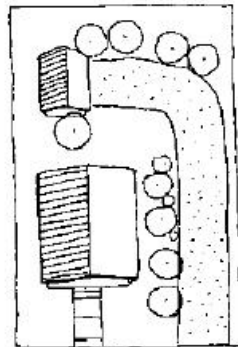

Where there is no alley and space permits, a side-yard driveway may be acceptable. Garages should still be placed behind the house, and the drive should be appropriately landscaped.

(Courtesy of Metro Historic Landmarks Commission)

NC22 Maintain the historic rhythm of the streetscape. The space between new construction and existing structures should fall within 20 percent of the average spacing for the block.

NC23 Maintain historic setback patterns. In order to maintain the continuity of the streetscape, setbacks for new construction should either match that of adjacent buildings where all share the same setback or be within 20 percent of neighboring structures in areas with varied setbacks.

NC24 Ensure that the roofs of new buildings relate to those of neighboring historic structures in pitch, complexity, and visual appearance of materials.

NC25 Follow the precedent set by adjacent buildings when designing rooflines for infill construction. Where the predominant form is flat, built-up roofs are preferred. Where the predominant form is complex and steeply pitched, that is preferred. In blocks characterized by shallow-pitched roofs and pronounced overhangs with exposed rafters, these elements should be incorporated.

NC26 Design new construction to emphasize the existing cornice line on each block where this is a character-defining feature.

NC27 Integrate mechanical systems into new construction in such a way that rooftops remain uncluttered.

NC28 Make provisions for screening and storing trash receptacles when designing new construc-

tion.

NC29 Design new construction so that the orientation of the main roof form is parallel with the majority of other roofs on the street, where roof forms are relatively consistent and a character-defining feature.

NC30 Use masonry types and mortars that are similar to surrounding buildings in designs for new construction. Red brick is the most common masonry material found throughout the city's historic districts.

NC31 Incorporate stone or cast-stone sills and lintels into new construction designs on blocks where such elements are character-defining features.

NC32 Do not use modern "antiqued" brick in new construction.

NC33 Design new construction to have a raised masonry foundation, which is compatible in proportion and height with surrounding buildings. Foundation materials may be of a warm-toned poured concrete, split-face concrete block, or stuccoed concrete block that has a uniform, textured appearance.

NC34 Incorporate front porches on blocks where they are character-defining features. Design of new porches should be compatible with the form, scale, and detailing of surrounding buildings. On blocks where porch columns are prevalent, new columns should always consist of a base, shaft, and capital, and convey the appearance of actually holding up the porch roof.

NC35 Design porches on newly-constructed buildings so that the floor is even with or a maximum of one step below the corresponding floor of the house, the ceiling is even with that of adjacent rooms, the floor is at least six feet deep, the rhythm of the porch bays matches the façade's pattern of solids and voids, and the porch fascia board matches the height of the window head.

NC36 Design new garages or other secondary structures so that they complement the scale, roof form, setback, and materials of adjacent secondary structures.

NC37 Site new garages adjacent to alleys where present. Review the garage prototype insert that identifies styles appropriate to preservation districts when planning a garage construction project.

NC38 Use an exterior sheathing that is similar to those of other surrounding historic buildings. While use of wood siding is preferred, vinyl siding may be used for new construction, but only in areas where the predominant historic construction material is wood.

NC39 Use of smaller, single garage doors rather than expansive double or triple doors is preferred.

NC40 Orient the roofline of a new garage so that it is parallel with the main house or follow the predominate pattern of existing secondary structures where such a pattern exists.

NC41 Roof pitch should be no less than one in six. Where the roof form of the main house is character-defining, owners are encouraged to echo the form of the main house.

NC42 Design new construction so that access to off-street parking is off alleys or secondary streets wherever possible.

NC43 Incorporate storm-water management provisions into the design of new construction, so that any related runoff will not adversely impact nearby historic resources.

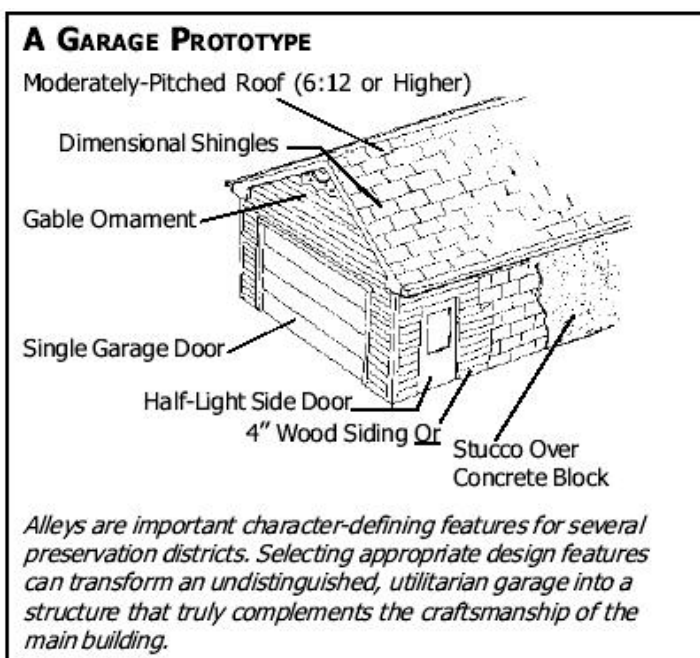

(Courtesy of Metro Historic Landmarks Commission)



The size of this addition and its relationship to the house are appropriate.

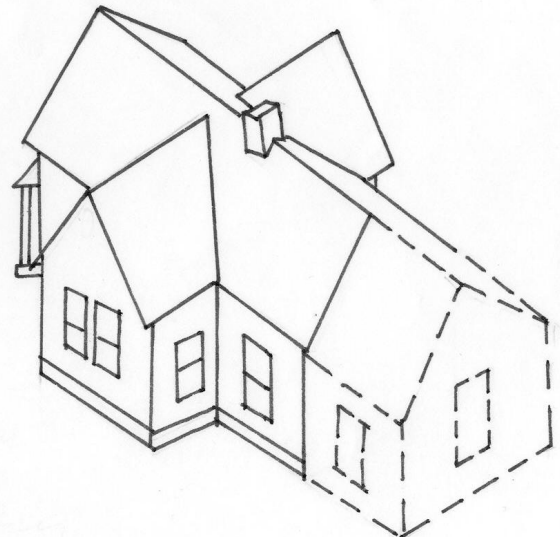

This addition is well placed and sized.



Visible additions to the America Foursquare at 109 South Third Street would disturb its historic symmetry of form and façade.



The modern house at 102 West Brashear Avenue followed the historic design and materials precedents set by its neighbors. (NCPZ Digital Archive)



The modern house at 212 West Flaget Avenue is also well-done infill construction. (NCPZ Digital Archive)

SECTION 6

NON-RESIDENTIAL DESIGN



Third Street and Broadway Avenue (NCPZ Digital Archive)



Old Library Building, Courthouse Square



Peoples Bank Building, 131 North Third Street (NCPZ Digital Archive)



Nelson County Courthouse (NCPZ Digital Archive)



First Baptist Church, 315 North Second Street



United Methodist Church, 116 East Flaget Avenue (NCPZ Digital Archive)



Bowman-Cherry Center, 403 North First Street (NCPZ Digital Archive)

ARCHITECTURAL DETAILS and FEATURES

Architectural features define commercial building styles and provide unique finishes to buildings with similar forms and materials. They should be retained, repaired, and replaced with similar features if missing.



126 North Third Street

AR1 Retain historic architectural details.

AR2 Repair historic architectural details with matching materials if they become damaged.

AR3 Leave historic architectural details visible.

AR4 Replace historic architectural details if they are missing or so badly damaged that replacement is necessary. Replacement elements should consist of matching materials, be the same size as the original elements, and be chosen based on physical or photographic evidence.

AR5 Use wood epoxies to strengthen or reshape small rotted or deteriorated portions of wooden elements.

AR6 Cut out larger deteriorated pieces of wooden elements and piece in wooden replacement pieces.

AR7 If replacement is required, replace wooden elements with new wooden elements.

AR8 Do not construct new features that are either falsely historical (characteristic of periods prior to the building's actual construction) or are incompatible with the building or historic district in terms of size, scale, material, or color.

AR9 Keep surfaces of metal and wooden architectural details painted as an important part of retention.

AR10 Photographically document architectural features that are slated for reconstruction or replacement prior to the removal of any historic fabric.

AR11 Use historical, pictorial, and physical documentation when undertaking the reconstruction of a missing feature. If there is not sufficient information to determine the original design, a new design should be prepared that is compatible with the architectural character of the building and the district. Conjectural or falsely-historical designs are not appropriate.

AR12 Do not remove deteriorated metal features and replace them with elements that do not convey the same visual appearance. Do not remove such a feature and not replace it at all.

AR13 Clean metal features only where such cleaning will not damage historic color, texture, or patina. Any cleaning treatment should use the gentlest means possible and first be tested in an inconspicuous location to determine potential adverse effects.

AR14 Use only those cleaning treatments that are appropriate to the type of metal being cleaned.

AR15 Clean soft metals, such as tin, lead, copper, terneplate, and zinc, using appropriate chemical methods, since blasting methods damage and pit their surfaces.

AR16 Clean hard metals, such as cast iron, wrought iron, and steel, with hand scraping or wire brushing to remove corrosion and paint buildup. Low-pressure grit blasting may be used only if additional cleaning is required.

AR17 Do not expose metal types that require protection from the elements or apply paint or other coatings to metals that were historically meant to be exposed, such as copper, bronze, or stainless steel.

AR18 Reapply an appropriate paint or other coating system to previously painted metal features after cleaning. Failure to do so will result in accelerated corrosion of the metal or alloys.

AR19 Do not place incompatible metals together without a protective barrier since this can result in galvanic corrosion, such as copper corroding cast iron, steel, tin, or aluminum.



The brick corbelling in the 200 block of North Third Street helps to define historic character.



This cornice, at 229 North Third Street, should be retained.



Maintain the painted surface of features like the cast iron columns and pilasters at 130 North Third Street.



Cast iron architectural features, like pilasters and cornices, decorate commercial buildings like those at 202 and 204 North Third Street.

AWNINGS

Historically, awnings were common features in commercial districts.



111 North Third Street

AW1 Awnings should fit the opening to which they are applied. Shed awnings should be used for rectangular openings and arched awnings for arched openings.

AW2 Design awnings to complement existing architectural features and period and style of the building. They should not overwhelm the facade.

AW3 Install awnings made of weatherproofed canvas of a traditional form. Fiberglass, metal, plastic, and back-lit awnings that have contemporary shapes are inappropriate and visually intrusive.

AW4 Select an awning color that complements

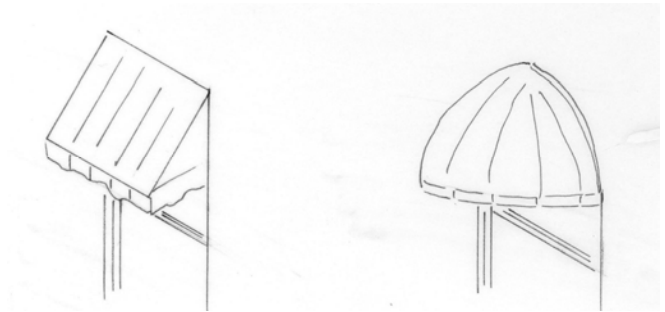

These awnings appropriately mirror the shapes of their openings.

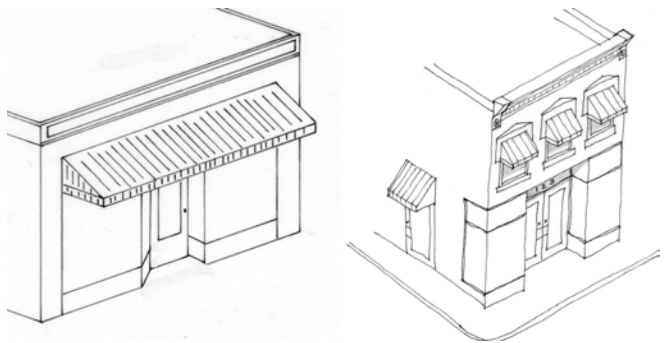

The placement of these awnings, between storefront pilasters or above individual windows and door, are appropriate.

the building, with solid colors and narrow or wide stripes running perpendicular to the building being the preferred patterns.

AW5 Install storefront awnings between pilasters or columns.

AW6 Install awnings in a way that does not harm the building and does not interfere with the visibility of architectural details. Hardware installation should be limited to that which is required for structural stability and should be driven into mortar joints rather than into masonry.

AW7 Attach awnings between the window display area and the signboard or second floor window sills. Awnings should be attached below the transom line where historic prism glass is present and building scale allows.

AW8 Install awnings so that the valance is no lower than seven feet above the sidewalk.

AW9 For awning signage, refer to the signs section of this manual.

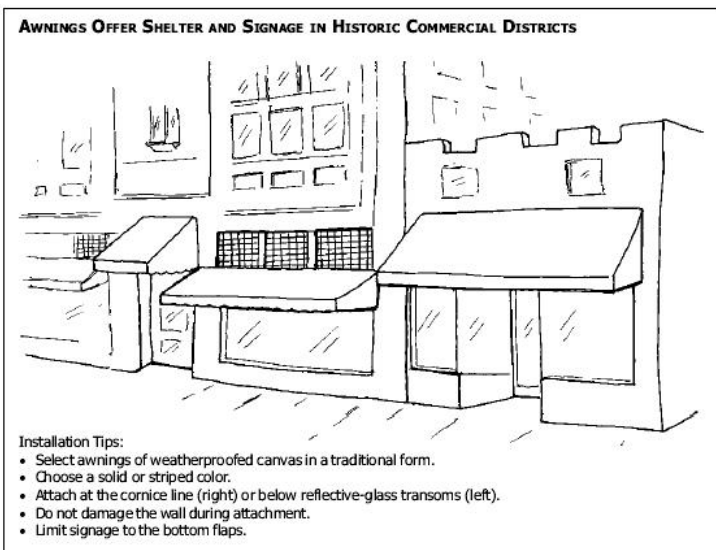

(Courtesy Metro Historic Landmarks Commission)

DOORS

Historic doors and entrances should be retained, repaired, and, if replacement is required, replaced with compatible design doors.



130 North Third Street

DO1 Do not alter the character of entrances by either removing historic elements or through the addition of elements for which there is no historic precedent.

DO2 Retain and preserve historic doors, their surrounding entrance openings, and other surrounding elements such as transoms.

DO3 Photographically document doors or entrance features that are slated for reconstruction or replacement prior to the removal of any historic fabric.

DO4 Use historical, pictorial, and physical documentation when undertaking the reconstruction of a missing entrance or feature. If there is not sufficient information to determine the original

design, a new design should be prepared that is compatible with the architectural character of the building and the district. Conjectural or falsely historical designs are not appropriate.

DO5 Repair damaged historic doors or related elements using methods and materials that allow for the retention of as much original fabric as possible and that do not damage the original fabric.

DO6 Replace historic doors or related elements which are missing, or are so badly damaged that replacement is necessary, with those that match the original in style, size, and materials. Use replacement doors with a wide stile and with glass sized proportionally to display windows and kickplates sized proportionally to bulkhead panels.

Door Parts

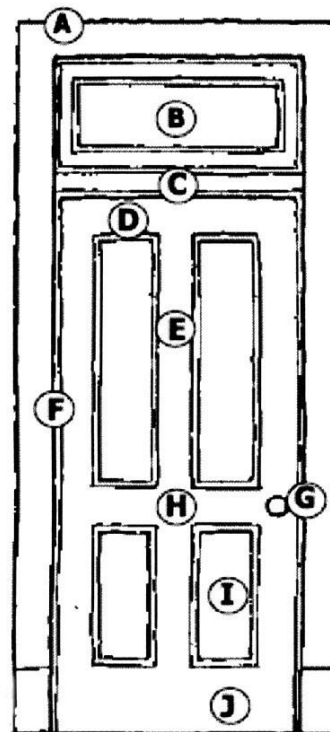

- A. Head Casing
- B. Transom
- C. Transom Bar
- D. Top Rail
- E. Cross Rail
- F. Hinge Stile
- G. Lock Stile
- H. Lock Rail
- I. Panel
- J. Bottom Rail

(Courtesy of Metro Historic Landmarks Commission)

DO7 Use only those replacement doors that duplicate the design, proportion, and arrangement of paneling and glazing as the original.

DO8 Do not replace historic double-leaf doors with a single door.

DO9 Replacement of non-original, non-historic doors with new doors that are appropriate to the period and style of the building and are the size of the original opening is recommended.

DO10 Do not alter original openings to accommodate stock doors.

DO11 Differentiate between primary and secondary doors, using the detailing of the doors or the articulation of the frame.

DO12 Do not add vestibules to facades unless there is historic precedent. Such additions alter the character, proportion, and massing of the façade.

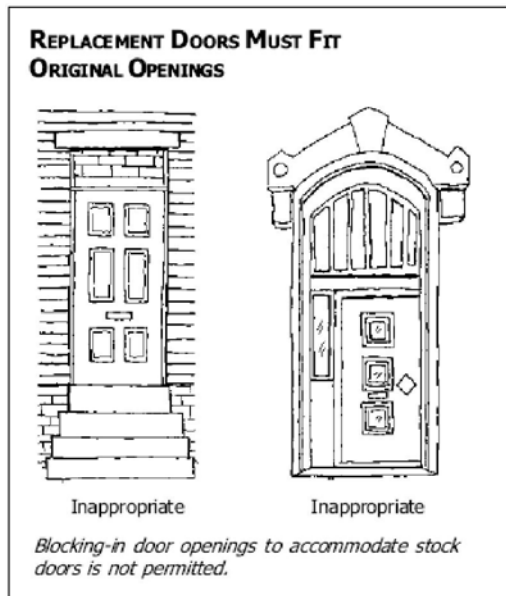

(Courtesy of Metro Historic Landmarks Commission)

storm doors should be painted or finished to match the inner door. Dark baked enamel or anodized frames are appropriate.

DO18 Use storm doors with dark baked enamel or anodized frames.

DO19 Use storm doors that are full-view or plain design.

DO20 Install security bars only on rear or side elevations and in such a way that they do not obscure the architectural character of the original doors or damage historic fabric. Commercial security grilles should retract out of sight during business hours and preferably be mounted inside the glass. Painting security bars an unobtrusive color is recommended.

ENTRANCE TRIM MAINTAINS ARCHITECTURAL BALANCE—IT SHOULD NOT BE REMOVED

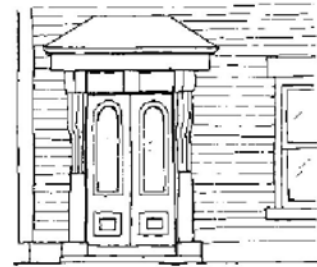

The original door surround frames the entry, giving it a feeling of substance and solidity.



Removal of the door surround disrupts the historic proportion of the entrance. The door appears to be ungrounded, "floating" within the facade.

(Courtesy of Metro Historic Landmarks Commission)

DO13 Do not create new entrances on elevations that can be seen from the street.

DO14 Retain historic security doors.

New security doors should consist of full-view or plain designs.

DO15 Install only screen doors or storm doors that are simple with a narrow-frame design and that are full-view to enable the inner door to be seen.

DO16 Security bars should be placed on rear or side elevations not visible from the street.

DO17 Metal storm doors should be

HISTORIC PANEL AND GLASS CONFIGURATIONS SHOULD BE CONSIDERED

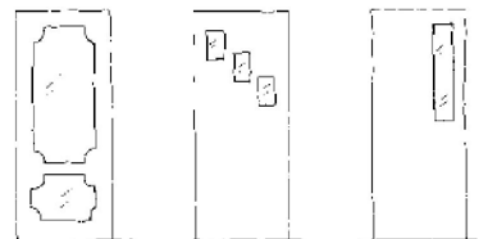

Inappropriate Replacements for Historic Doors

Replacement doors should have the same visual appearance as the original. Modern flush doors without paneling or with modern glazing configurations are not permitted. Six-panel doors are also not appropriate for most local preservation districts or landmarks.

(Courtesy of Metro Historic Landmarks Commission)



Double doors like 120 North Third Street's were commonly employed for historic storefront entrances.



Single doors like the one at 116 North Third Street were often used for secondary commercial entrances.

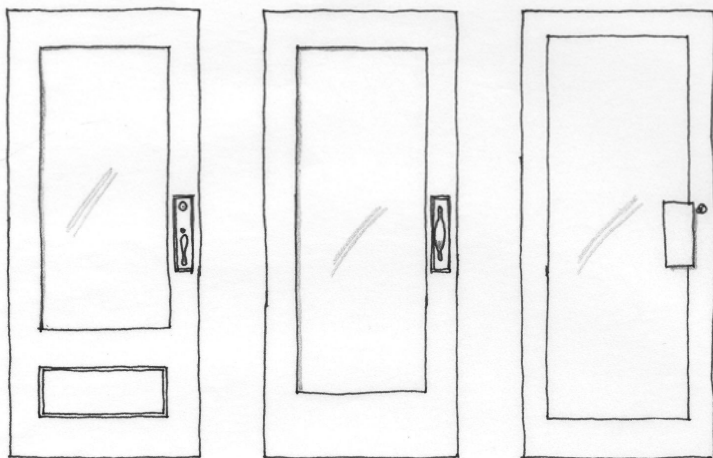

These designs, as well as those shown in the photographs, are appropriate for replacement commercial doors.

STORMS AND SCREENS SHOULD NOT CONCEAL

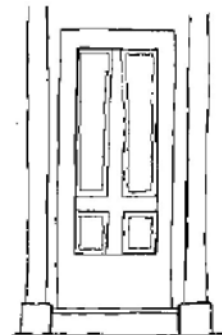

Appropriate

The historic door's appearance can be seen.

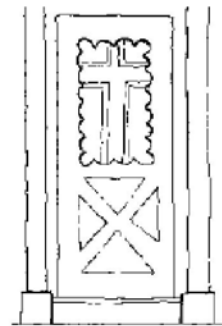

Inappropriate

The historic door's appearance is obscured.

If needed, storm doors and screen doors that have a narrow frame, which allow the door behind it to be seen, are preferred.

(Courtesy of Metro Historic Landmarks Commission)

FENCES AND WALLS

Historic fences and walls should be retained and repaired. New fences and walls should use historically appropriate designs and materials.

F1 Consider the relationships that exist between the site and structure when making exterior alterations. Changes to one will affect the other. A primary goal should be to maintain a complementary relationship.

F2 Retain historic fences and walls.

F3 Repair historic fences and walls using matching materials.

F4 Do not install front-yard fencing where there is no historic precedent.

F5 Use historically appropriate fencing materials, such as metal for pre-1930 houses and wood.

F6 Use materials that match existing sections of historic fencing in material, height, and detail when carrying out limited replacement projects. If an exact match cannot be made, a simplified design is appropriate.

F7 Use historically appropriate fence types for areas visible from the street, such as metal fences of simple design, wood picket fences, and plank fences.

F8 Use substitute materials only if they match the site and building in materials and design and are not visible from the street.

F9 Paint wood picket and plank fences white or beige or stained with a light color, and paint metal fences black.

F10 Use privacy fences that are solid wood boards and that do not obstruct the historic viewscape from the street.

F11 Use solid wood board fences with flat or arched tops.

F12 Install any rear- or side-yard privacy fencing so that it presents the finished side out.

F13 Do not install chain-link, split-rail, or wovenwood fencing, or concrete-block walls in areas that are visible from a public way. Opaque fencing, such as painted or stained pressure-treated wood, may be permitted with appropriate design.

F14 Use materials that match the existing

character of the original when replacing retaining walls or curbing. If an exact match cannot be made, a simplified design is appropriate.

F15 Do not install masonry walls in street visible locations unless they are used to retain earth at changes in grade, screen service areas, or unless a historic precedent exists.



This fence at 122 East Stephen Foster Avenue screens a dumpster and utilities equipment. (NCPZ Digital Archive)



At 101 North Third Street, the fence screens a parking lot and HVAC system from view. (NCPZ Digital Archive)



This fencing surrounds a dumpster on Raspberry Alley. (NCPZ Digital Archive)

GUTTERS and DOWNSPOUTS

Gutters and downspouts should be used to protect buildings from water damage. They should be located along rear and side elevations.



123—125 North Third Street

G1 Locate gutters and downspouts on rear elevations or other locations where not readily visible from the street and away from architectural features.

G2 Half-round replacement gutters that are of a simple design and do not alter the character of the trim, or in limited cases ogee profile gutters, are preferred. Synthetic materials painted to match the trim color are acceptable.

G3 Do not destroy historic detail when installing replacement gutters. If synthetic materials are used, they should be painted to match the trim color.

G4 Do not use unpainted galvanized steel gutters or downspouts, which rust and stain adjacent materials. These gutters should be painted after a period of weathering. Vinyl gutters and downspouts should be avoided due to their short life expectancy.

G5 Leave historically exposed rafter ends and eaves open and uncovered.

G6 Use round downspouts.

G7 Use splash blocks to channel water away from buildings.

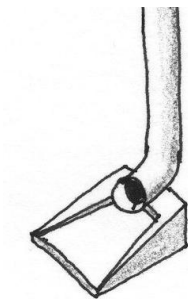

Splash blocks guide drainage away from the building.

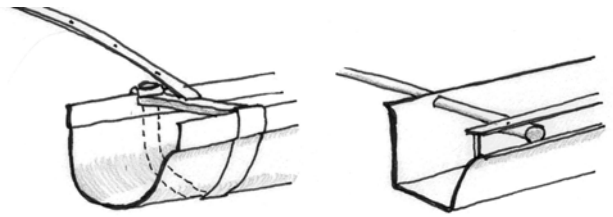

Half-round gutters like the one on the left are preferred. Ogee gutters like the one on the right may be substituted in some cases.



Placement of these gutters and downspouts, on the rear of the building at 111 North Third Street, is appropriate.

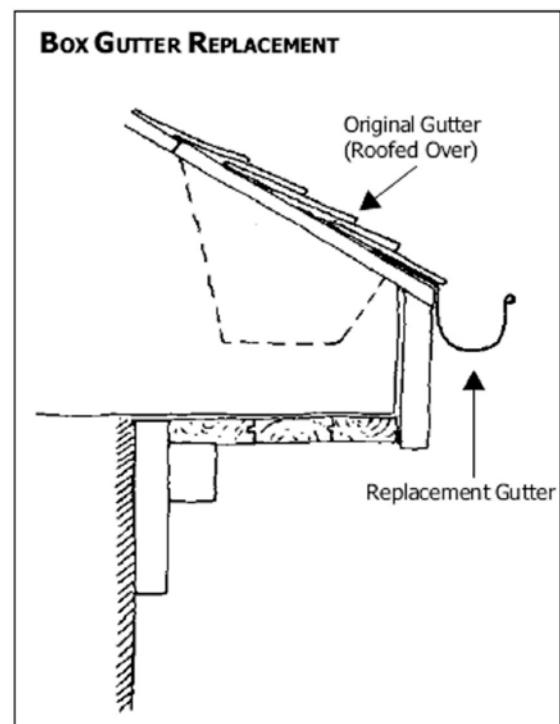

(Courtesy of Metro Historic Landmarks Commission)

LIGHTING

Historic light fixtures should be retained and repaired as needed. If new or replacement fixtures are added, they should be simple in design and materials so as not to detract from the historic character of the district.



101 North Third Street

- L1** Retain historic light fixtures.
- L2** Repair historic light fixtures using materials that match the original in size, shape, and design.
- L3** If replacement is required, replace historic lighting fixtures with those of similar design and materials.
- L4** New lighting fixtures should be made with historically appropriate materials and should be compatible in size, scale, and style with their placement on historic buildings and sites. Use concealed or simple fixtures or fixtures that match the building's time period.

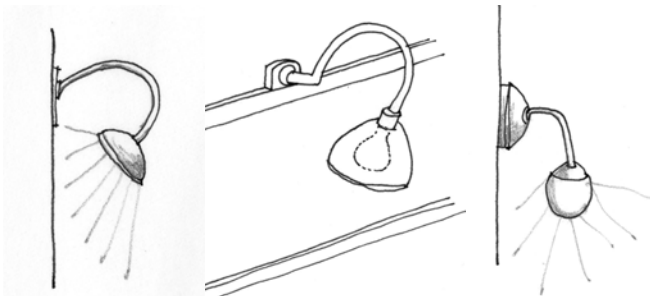

These simple, metal fixtures are appropriate.

L5 Use understated fixtures when installing any type of exterior lighting. Fixture attachment should be done so as not to damage historic fabric. Fixtures should not become a visual focal point.

L6 Do not light parking areas, driveways, or architectural features in a harsh manner. An average illumination level of .5 foot candles is sufficient. Light should be directed down and away from all traffic and neighboring properties.

L7 Illuminate signage externally. Lighting of free standing signs shall be concealed and ground-mounted. Illumination of signs shall be directed away from all traffic and from all adjoining neighboring properties. The intensity of lighting shall not exceed 15 foot candles at any point on the sign face.

L8 Light signs by spotlights, not internally.

L9 Use high-pressure sodium or metal halide lights to create a soft illumination where site or streetscape lighting is desired.



These replacement lights are appropriately directed toward the signs; the ones on the left are simple in design and those on the right are concealed.

MASONRY

Brick is a common building material for historic commercial buildings. Brick and other masonry construction materials should be retained, repaired, and, if repair is not possible, replaced with matching materials. Keeping water out of the masonry surface and using soft mortar in repairs are the most important steps in maintaining brick walls and details.



200 block of North Third Street

M1 Do not construct new masonry features that are either falsely historical (characteristic of periods prior to the building's actual construction) or are incompatible with the building or historic district in terms of size, scale, material, or color.

M2 Do not cut new openings into exterior walls on elevations that can be seen from a public way. Creating an opening for the installation of an air conditioning unit, for example, is not appropriate for an elevation that is visible from a public way.

M3 Photographically document architectural features that are slated for reconstruction prior to the removal of any historic fabric.

M4 Match the existing bonding pattern, coursing, color, size, strength, and pointing mortar of masonry when replacing a section of brick wall. Bricks should always be toothed-in to historic brickwork, to disguise the joint between new and old.

M5 Do not remove or rebuild substantial portions of exterior walls if such an action would adversely impact a structure's historic integrity.

M6 Make sure that any exterior replacement bricks are suited for exterior use.

M7 Do not replace sections of historic brick with brick that is substantially stronger.

M8 Repoint only those joints that are no longer sound. Do not remove all joints, sound and unsound, in an effort to achieve a uniform appearance when repointing. Large-scale removal of mortar joints often results in damage to historic masonry.

M9 Remove unsound mortar joints carefully with hand tools that are narrower than the mortar joint. Power tools should not be used, because they have the potential to scar adjacent masonry.

M10 Remove unsound mortar to a depth of two-and-a-half times the width of the joint or to sound mortar, whichever is greater.

M11 Match historic mortar joints in color, texture, joint size, and tooling when repointing.

M12 Use a mortar mix that is compatible with historic masonry. Repointing mortar should be equivalent to or softer than the original mortar. When repointing mortar is harder than the surrounding masonry, as is the case with many modern mixtures, moisture can not escape through the joints. Trapped moisture will crystallize within the walls and fragment surrounding brick and stone.

M13 If possible, have your mortar analyzed. In order to determine an appropriate mortar mix for individual historic structures, it is recommended that property owners have a sample of the original mortar sent to a lab for analysis. If this is not feasible, a high-lime and low-Portland-cement content mortar mix (one part cement, one part lime, and six parts sand) is frequently acceptable.

M14 Do not attempt to remove joints that have been replaced using a very hard mortar or in an unworkmanlike manner until natural weathering has begun to weaken and crack them. Removal prior to that time would likely damage the masonry units.

M15 Do not use synthetic caulking compound to repoint historic masonry.

M16 Have realistic expectations of how the cleaned masonry surface will appear. Remember, it is better to underclean than overclean. A like new appearance is rarely desirable.

M17 Make sure that your contractor has a clear understanding of the physical and chemical properties of your masonry before proposing or testing any chemical treatments. Such treatments, if improperly applied, can result in permanent damage that significantly outweighs any benefits of cleaning.

M18 Test proposed cleaning treatments in an inconspicuous area of the building to evaluate potential adverse effects to the masonry. Observation over a complete seasonal cycle is preferable, so that long term effects may be ascertained. If chemical treatments are found to be acceptable, be sure that those applying the treatments follow all manufacturers instructions.

M19 Do not use sandblasting or high-pressure water to clean historic masonry. The process of sandblasting or cleaning buildings using water pressure greater than 300 psi removes the tough outer protective surface of the brick and loosens mortar joints, accelerating deterioration.

M20 Do not clean masonry on buildings with deteriorated mortar joints. Such masonry should be properly repointed prior to cleaning to ensure that water does not penetrate the wall during the cleaning process.

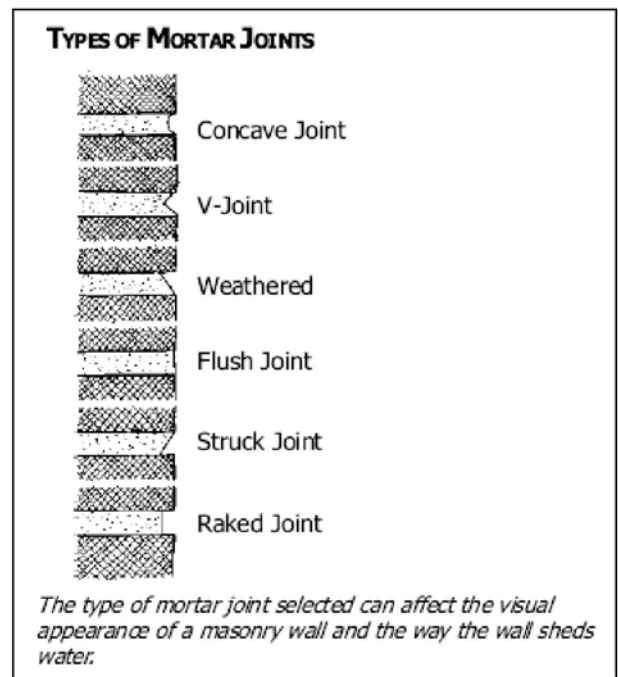

(Courtesy of Metro Historic Landmarks Commission)

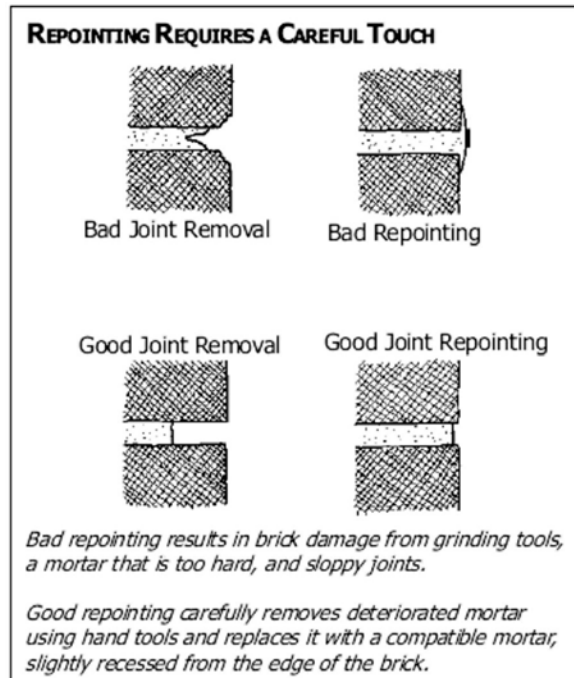

(Courtesy of Metro Historic Landmarks Commission)

M21 Do not use any type of water or chemical-based cleaning systems when a possibility for freezing temperatures exists. Masonry cleaning should not be undertaken until the temperature will remain above 50 degrees for 72 hours after cleaning.

M22 Remove graffiti as soon as possible, beginning with the gentlest means possible and taking care not to inadvertently etch an outline of the graffiti onto the wall.

M23 Use solvent-based chemical strippers to remove paint from previously painted masonry only after testing its effectiveness and evaluating its potential to damage brickwork. Testing should be carried out in an inconspicuous location.

M24 Do not paint masonry or stucco that has never been painted. While one layer of paint may not affect the appearance of the masonry or stucco, accumulated layers will eventually obscure decorative detail.

M25 Paint previously painted masonry a color that is close to its existing color, approximates a natural masonry color as approved, or is recommended by the staff. Staff is available to consult with you on colors.

M26 Use a breathable masonry paint that is compatible with and can create a strong bond with existing paint.

M27 Make sure that areas of patched stucco match the strength, composition, color, and texture of the original to the greatest degree possible.

M28 When patching stucco, cut back the successive layers to provide a key for the new layers to prevent new cracking.

M29 Carry out stucco repairs so that the dimension between the surface of the stucco and adjacent finishes remains unchanged.

M30 Do not install stucco, Dryvit, or permatone-type cladding over historic masonry or wood siding.

M31 Do not resurface historic masonry with exterior insulation.

M32 Use a masonry or terra cotta chimney cap if needed. Metal chimney caps are not historically appropriate.

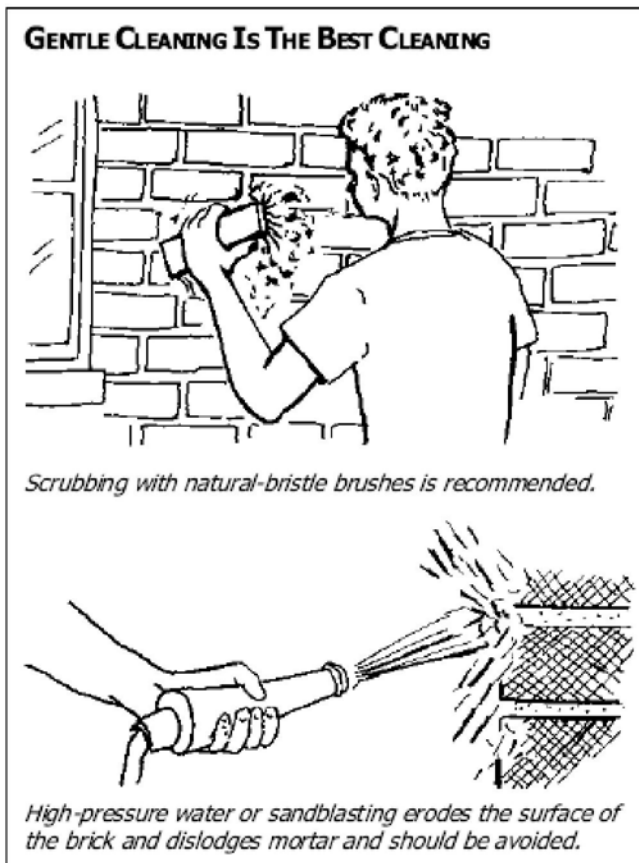

(Courtesy of Metro Historic Landmarks Commission)



The contrast between concrete and brick is the main decorative feature of the building at 122 North Third Street.



If the brickwork at the Opera House needs to be re-pointed, the original mortar profile should be examined, then replicated.

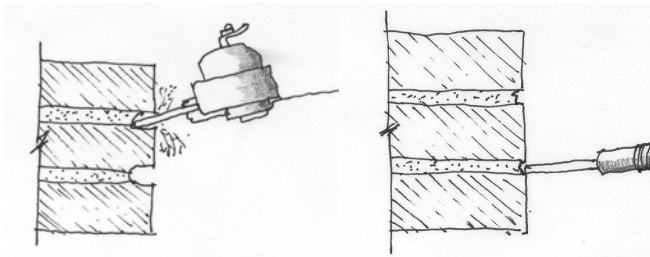

Electric tools are damaging; hand tools should be used instead.



The masonry surfaces of 101 North Third Street should be protected from damaging treatments.



Stone surfaces such as on Talbott Tavern should be left exposed, not painted.

MECHANICAL EQUIPMENT, TRASH COLLECTION AREAS, and OUTDOOR STORAGE AREAS

Roof-top and ground-mounted equipment and trash collection and outdoor storage areas shall be screened from view using placement and/or appropriate materials.



123—125 North Third Street

ME1 Locate mechanical equipment and trash collection and outdoor storage areas behind buildings and completely screened from public view.

ME2 Screen equipment and trash collection and outdoor storage areas using landscaping, lattice panels, or similar materials that will form an opaque (solid) screen.

ME3 Locate mounted equipment, such as meters or window A/C units, on the rear or side elevations that are not visible to the public.



The rear elevations of buildings like this one at 222 North Third Street are appropriate locations for meters and other support elements. (NCPZ Digital Archive)

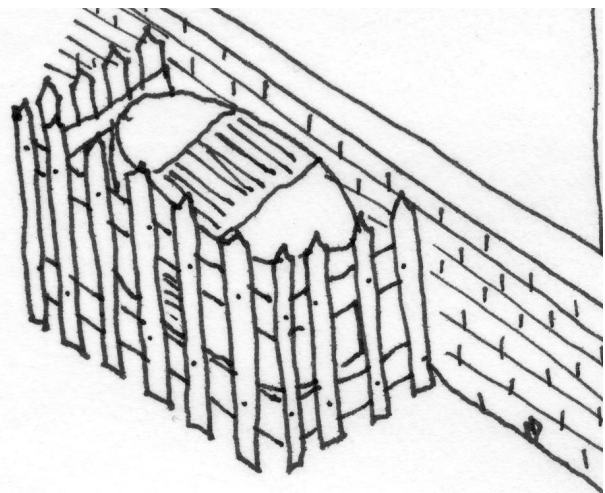

Lattice panels or fencing can help minimize the visual impact of mechanical equipment.



Plants like these at 111 North Third Street can be useful in screening equipment from view.

PAINT

The painted finish of metal and wood portions of buildings should be maintained in colors that complement and contrast with the buildings. Unpainted masonry surfaces should remain unpainted unless paint is needed for protection.



100 West Flaget Avenue

P1 Do not paint masonry or stucco that has never been painted. Paint is difficult to remove, accumulated layers will obscure decorative detail, and paint coatings (even breathable paints) will affect a wall's vapor transmission performance. The presence of a lead oxide wash does not constitute a precedent for painting a building.

P2 Maintain the painted surfaces of wood and metal trim and building components.

P3 Paint wood and metal trim and building components in colors that complement and contrast with their building.

P4 Leave unpainted brick buildings unpainted unless the surface has been damaged and paint is needed to preserve it. If paint is required, use colors typical of bricks like red, brown, or tan.

P5 Do not remove paint from wood by sandblasting or other abrasive methods.

P6 Remove paint only if it is not protecting damaged masonry.

P7 When removing paint from previously

painted masonry, use gentle treatments that have been previously tested in an inconspicuous location. Do not sandblast or use acid-based cleaners.

P8 Use a breathable masonry paint that is compatible with and can create a strong bond with existing paint, only on previously painted masonry.

P9 If painting previously painted masonry, select a color that matches the existing color, approximates a natural masonry color as approved, or is recommended by the staff. Staff is available to consult with you on appropriate colors.

WHERE PAINT REMOVAL IS REQUIRED, A GENTLE APPROACH IS BEST

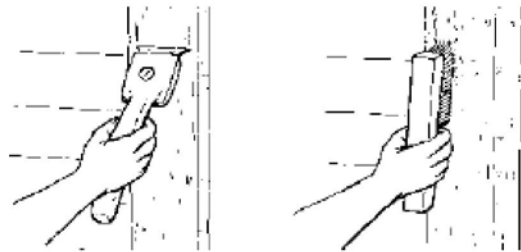

Handscraping and sanding is recommended for wood.



Hot-air guns and heat plates are not recommended for wood.

Test a chemical stripper in an inconspicuous area before applying it to masonry.

(Courtesy of Metro Historic Landmarks Commission)

P10 Have paint samples analyzed when possible. Paint serratation studies can determine historic pigments and appropriate colors for repainting by analyzing a paint sample under special lighting conditions to ascertain specific color, hue, and value of paint layers.

P11 Do not expose metal types that require protection from the elements or apply paint or other coatings to metals that were historically meant to be exposed, such as copper, bronze, or stainless steel.

P12 Paint replacement gutters, downspouts, metal-frame screen and storm doors and windows, roof-vent assemblies, and fire escapes to match wall, trim, cornice, or roof color of the house, whichever is most effective in reducing the visibility of these elements.

P13 Be aware that historic structures often contain hazardous substances, such as lead paint and asbestos. Contact the Health Department regarding proper methods of removal and disposal.



Retaining the painted finish of the wooden window sash at 204 North Third Street contributes to historical character and building maintenance.



The color of its brick exterior and the contrast between bricks and concrete dominate the appearance of the Old City Hall at 207 North Third Street.

REAR ELEVATIONS

Historically, rear elevations were private spaces or generally not used for public access. They remain appropriate locations for service elements like fire escapes and other stairs and mechanical components. In recent years adding rear parking has made rear spaces in Bardstown more accessible and caused them to be used for public entrances. Rear elevations are appropriate locations for awnings and decks.



123—125 North Third Street

RE1 Install fire escapes or stairs constructed of metal or wood in colors compatible to the buildings or enclosed with wood, brick, or painted stucco on the rear elevation.

RE2 Install mechanical equipment and trash collection and outdoor storage spaces along rear elevations in accordance with the guidelines for these elements.

RE3 If awnings are installed on rear elevations, install them in keeping with the awnings guidelines provided herein.

RE4 Construct decks to be unobtrusive and use simple design and materials, such as metal or wood, and colors compatible to the building. Decks must comply with the guidelines for new construction provided herein.



The rear elevation of 222 North Third Street maintains a simple appearance. (NCPZ Digital Archive)

ROOFS

Flat roofs are common characteristics of commercial buildings. Roof shape, be it flat or sloped, should be retained, and parapets or other roofline features should be retained.



100 block of West Flaget Avenue

R1 Retain historic roof shape, size, pitch, materials, and features.

R2 Substitute materials such as rolled asphalt may be acceptable should replacement roofing materials be required on flat roofs not visible from the street.

R3 Retain and repair roofline features.

R4 Use only replacement materials that closely match the original roofing material in color, texture, and profile. Possible substitute materials include asphalt shingles, dimensional shingles, or cement tiles.

R5 Use copper, lead-coated copper, terne-coated stainless steel, or terne metal when replacing a historic metal roof with in-kind materials. While copper roofs may be left unpainted, terne-metal roofs should be painted either muted red or green, traditional roof colors. Replacement with in-kind materials is recommended in order to preserve the visual appearance of the original.

R6 Make sure that the proportion of the seams and trim on replacement metal roofing matches that of the original. Commercial-grade architectural metal roofing systems should not be

used on residential architecture, because the scale is inappropriate.

R7 Retain ridge and hip tiles on historic tile roofs. Field tiles may be replaced with a compatible substitute material, such as a dimensional shingle in a color approximating the original. Ridge and hip tiles, however, should be reinstalled to maintain the roof's historic profile. Reinstallation of sound roof tiles and slates on smaller, secondary roof forms (porches, bay windows, etc.) is encouraged wherever possible.

R8 Remove existing roofing material when replacing non-repairable or non-historic roofing. Removing these underlying layers will prolong the life of the roof and help restore the original profile of the roof edge.

R9 Do not apply asphalt shingles over wood shingles. This will trap moisture and cause deterioration of the roof structure.

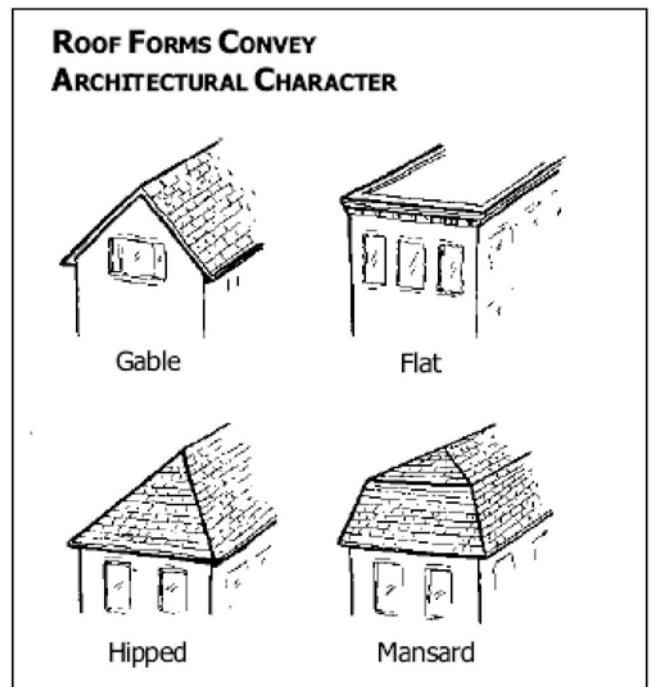

(Courtesy of Metro Historic Landmarks Commission)

R10 Base the reconstruction of any missing roof feature on historical, pictorial, and physical evidence. If such evidence is insufficient, the fea-

ture should be of a compatible new design rather than a falsely historical or conjectural reconstruction.

R11 Use new roof designs for additions or new construction that are compatible in size, scale, material, and color with the historic building and district.

R12 Use the form and detailing of severely deteriorated roof features, such as cupolas and dormers, or chimneys, to create appropriate replicas.

R13 Avoid having extensive areas of flashing visible. In some cases, portions of metal flashing may be covered by mortar or stucco.

R14 Do not destroy historic detail when installing replacement gutters. If synthetic materials are used, they should be painted to match the trim color.

R15 Leave historically exposed rafter ends and eaves open and uncovered.

R16 Make sure that any new roof-top additions do not compromise the structural integrity of the building and are completely screened from view.

R17 Install any new roof-top mechanical or service equipment in such a way that historic fabric is not damaged.

R18 Do not attach antennae, satellite transmitters, skylights, vents, air-conditioning units, decks, terraces, dormers, or solar panels that can be seen from the street. Skylights should be flush (not the bubble type) with curbs painted to match the color of the roof material. Consolidate antennae wherever possible.

R19 Do not introduce mechanical equipment or systems that may overload and compromise a historic building's existing structural system.

R20 Paint all roof vent assemblies to match the color of the roofing material.

R21 Do not install ridge vents on historic structures. They are non-historic approaches to attic ventilation.

R22 Replace historic roof details, such as decorative cresting and finials and metal ridge caps on slate roofs with in-kind materials or materials that are visually compatible.

R23 Install skylights only if they are not visible from the street.

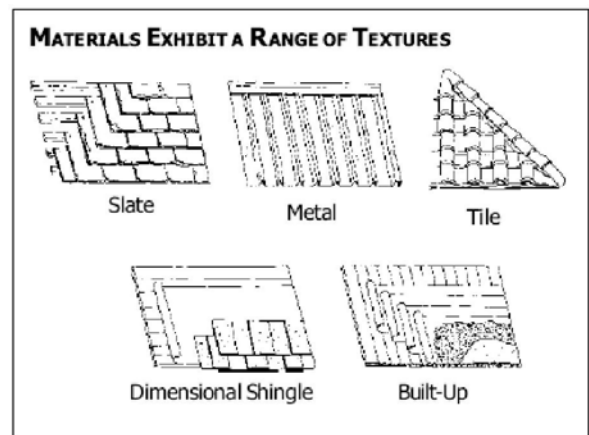

(Courtesy of Metro Historic Landmarks Commission)



The gable roof on the Old City Hall at 207 North Third Street contributes to its architectural style.



Roofline details contribute to the character of the Opera House.

SAFETY and ACCESSIBILITY

Fire escapes and ramps are not generally historic building components, but may be required for safety or accessibility. They should use inconspicuous placement, design, and materials to minimize their visual affects.



131 North Third Street (NCPZ Digital Archive)

SA1 Retain and repair fire escapes using matching materials.

SA2 If replacement is required, replace fire escapes with materials matching the original.

SA3 Use fire escapes only when required for safety reasons.

SA4 Locate fire escapes on a rear or side elevation where visibility from the street is minimal.

SA5 Where possible, locate ramps to assist people with disabilities on a rear or side elevation where visibility is minimal.

SA6 If construction of a ramp is required, take care that the original design of the entrance is not compromised and that historic materials are not damaged.

SA7 New fire escapes or ramps must be consistent with the design guidelines for new construction provided herein.



The fire escape on the Nelson County Public Library building on Public Square appropriately used placement behind and close to the building.

SIGNS

Signs in the downtown area should be of materials and placement consistent with historic patterns and trends.



97 West Flaget Avenue

SI1 Design signs to complement their surroundings. Signs should be integrated into the architectural design of the building and should not dominate the facade or interfere with adjacent buildings. Installation must comply with all other applicable city sign regulations.

SI2 Keep sign designs simple and easy to read. Use a limited number of lettering styles and colors, which reflect the character or the business and/or the building.

SI3 Design storefront-level signs that are primarily oriented to pedestrians and scaled appropriately.

SI4 Consider the following issues when installing a sign: its size, shape, and materials; where it will be positioned on the building; if and how it will be illuminated; and what typeface will be used.

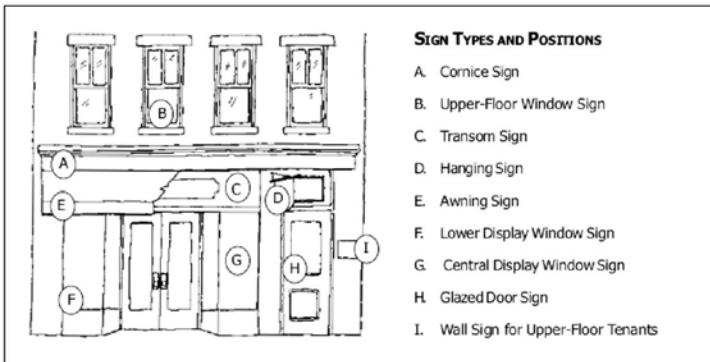

(Courtesy of Metro Historic Landmarks Commission)

SI5 Place attached wall signs over the unadorned frieze of a cornice or along the top of the storefront below the sill of the second-story windows. For residences, attach signs near doorways or on porches, where such features exist.

SI6 Keep flush-mounted signs under two-and-a-half feet in height. They should be installed above the display windows and below the second-story window sills. Lettering should be between eight and 18 inches high and occupy around 65 percent of the sign board.

SI7 Install window signs in such a way that lettering does not obscure the display area. The color of the letters should contrast with the interior space.

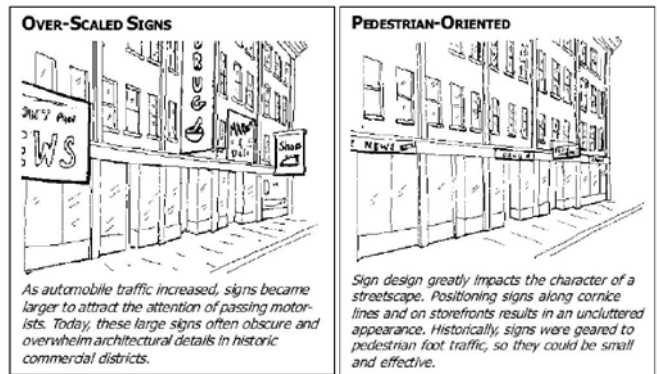

(Courtesy of Metro Historic Landmarks Commission)

SI8 Generally, signs project no more than five feet or half the width of the sidewalk, whichever is less.

SI9 Generally, do not install more than two signs on any storefront.

SI10 Do not install roof-top signs.

SI11 Use appropriate materials for signage, including painted or carved wood signs, painted wall signs, signs applied to canvas awnings, smooth-surface sheet-metal signs, and lettering applied to glass using gold leaf, paint, or etching.

SI12 Do not install plastic, over-scaled, neon, back-lit or internally lit fluorescent signs or awnings. Individual lettering and small logos may be illuminated within an opaque background. Signs that flash, move, or have inap-

appropriately scaled graphics should not be used. Reader boards are generally not appropriate.

SI13 Do not install a freestanding sign where an attached sign will accomplish the same end. They should be low to the ground and appropriately landscaped.

SI14 Do not install billboards within a historic district.

SI15 Use of portable and temporary signs may be approved with certain restrictions and in compliance with applicable local regulations.

SI16 Do not install marquees on any building other than an operating theater or hotel.

SI17 Do not light signs in a harsh manner. Lighting should enable the sign to be easily read, but should not be overdone. Concealed incandescent lighting is recommended. Internally lit, plastic box signs, bare spot lights, or high-wattage metal halide lights are inappropriate and should not be used.

SI18 Place signage in a location that benefits from existing interior lighting and street lighting.

SI19 All signs and visual elements must comply with the Bardstown Sign Ordinance.

- ELEMENTS OF A GOOD SIGN**
- Pedestrian oriented
 - Does not obscure architectural detail
 - Historically Compatible Material
 - Limited Number of Lettering Styles
 - Basic, Geometric Shape
 - Simple Attachment



Standing signs are used at 106 East Broadway Avenue and 116 East Stephen Foster Avenue.



Below a cornice like at 229 North Third Street is an appropriate location for signage.



Logo signs such as this sign at 129 North Third Street are encouraged.



Temporary signs are also sometimes appropriate for the historic district.

SITE

Elements of historic site plans, such as landscaping, paving materials, fencing, and public and private views, etc. are interrelated parts of historic properties and should be retained and restored.

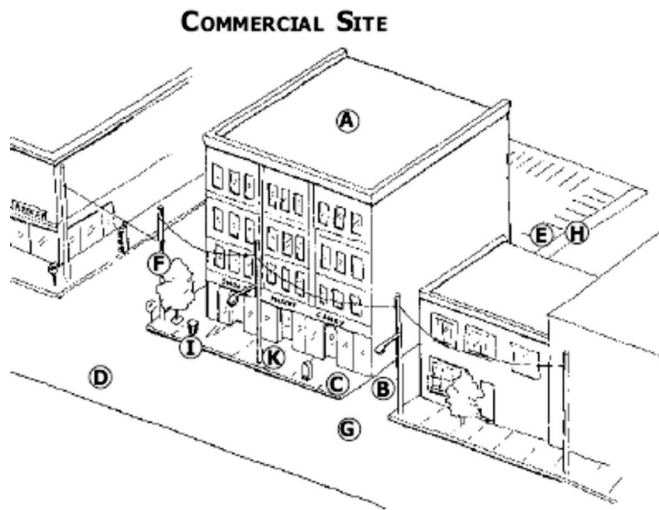

SITE CONSIDERATIONS

- | | |
|---------------------------|---------------------|
| A. Lot Size | G. Public Views |
| B. Building Setback | H. Private Views |
| C. Pedestrian Circulation | I. Street Furniture |
| D. Vehicular Circulation | J. Fencing |
| E. Parking | K. Lighting |
| F. Landscaping | |

(Courtesy of Metro Historic Landmarks Commission)

ST1 Consider the relationships that exist between the site and structure when making exterior alterations. Changes to one will affect the other. A primary goal should be to maintain a complementary relationship.

ST2 Retain established property line patterns and street and alley widths. Any replatting should be consistent with original development patterns.

ST3 Use paving materials that are compatible with adjacent sites and architectural character.

ST4 Restore and reuse historic paving materials for streets and sidewalks such as brick and hexagonal pavers and limestone curbing. Maintain original curbing whenever possible. The historic relationship between the road surface and edging should be preserved. Any replacement should use historic materials. If replacement with original materials is not technically or economically feasible, a substitute material may be used if it duplicates the color, texture, and visual appearance of the original.

ST5 Maintain brick, stone, or poured concrete steps wherever present. If replacement is required, original materials should be used. New construction should incorporate steps on blocks where they are a character-defining feature.

ST6 Do not harm historic resources through road widening or underground utility repair.

ST7 Install utility lines underground whenever possible.

ST8 Locate driveways and parking areas to the side and rear of properties. Access from alleys is preferred.

ST9 Construct new concrete or brick driveways with a solid surface.

ST10 Limit multi-car parking areas to locations out of view and behind buildings or at the rear of building sides. If needed, screening, such as solid brick, stone walls, or landscaping, can help screen parking.

ST11 Parking lots of a certain size should have a portion of the parking area dedicated to plantings that will soften the expanse of paving.



Trees and furniture create a welcoming atmosphere outside 114 North Third Street.

STOREFRONTS

Storefronts are one of the most important characteristics of commercial buildings; they typically occupy its entire first floor façade and they identify its retail function.



109 West Flaget Avenue

SF1 Do not remove historic materials from storefronts. Such materials as wood, cast iron, terra cotta, Carrara glass, ceramic tile, and brick contribute significantly to a storefront's architectural character.

SF2 Use historic materials where historic storefronts must be replaced in part or in whole.

Cast iron, limestone, or wood are appropriate materials for storefront replacement.

SF3 Retain all historic storefront elements, including later alterations that are historic in their own right.

SF4 Respect facade alterations that have attained historic or architectural significance in their own right. Work to incorporate such elements into any new storefront design or renovation. Do not attempt to recreate a conjectural historic design if there is insufficient physical or documentary evidence.

SF5 Do not remove later historically significant material to restore a building to an earlier period. For example, a 1910 storefront should not be taken back to a conjectural 1850s appearance.

SF6 Maintain the original scale, proportion, and organization of architectural elements (bulkheads, display windows, transoms, door, piers, and cornices) when renovating historic storefronts.

SF7 Use the original form and detailing of a storefront as a model, if extensive deterioration requires complete reconstruction. The reconstruction should convey the same visual appearance and use the same material as the original. Under no circumstances should a historic storefront be removed and not replaced.

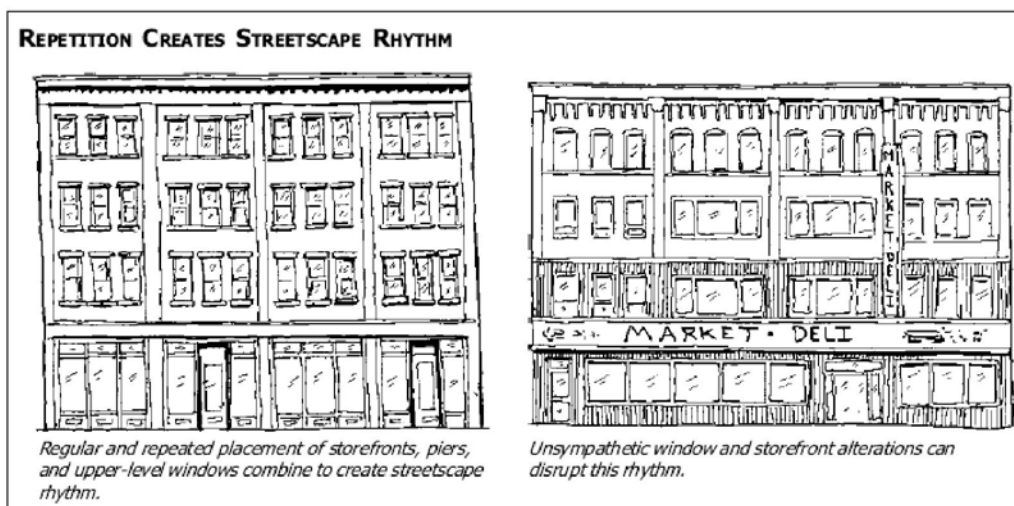

(Courtesy of Metro Landmarks Historic Commission)

SF8 Use historic, pictorial, and physical documentation to construct a historic storefront when the original is missing. The design may be an accurate restoration, if sufficient evidence exists, or a new design that is compatible with the size, scale, material, and color of the historic building and district.

SF9 Keep storefront designs within their original openings. Transitions from one facade to another should be clean and clearly defined.

SF10 Emphasize the transparent character of storefronts when implementing new designs or renovations. Generally, 60 percent of the wall surface at the sidewalk level should be transparent. Historically, merchandise seen in storefront displays was emphasized to a much greater extent than any ornament on the storefront itself.

SF11 Do not apply reflective or insulating film to window glass.

SF12 Do not use smoked, tinted, or reflective glass on building facades that can be seen from a public way.

SF13 Use large sheets of clear glass when replacement of storefront display windows is required.

SF14 Select replacement doors that reflect the storefront's original character. Doors should have large glass panels and be made of wood or painted steel or aluminum. They should not be overly decorated or possess inappropriate historic features.

SF15 Do not change or reorient the location of the main entrance of a storefront.

SF16 Install awnings that are consistent with the awning guidelines provided in this manual.

SF17 Maintain the commercial character of storefronts, even if they have changed use. Blinds or insulating curtains may be added for privacy and thermal performance.

SF18 Design replacement storefronts that are compatible with and complementary to their historic neighbors, but are recognizable as being of their own era.

SF19 Do not add elements to storefronts that have no historic precedent. Common examples of inappropriate alterations include the installation of coach lanterns, false mansard designs, small-paned windows, and inoperable shutters.

SF20 Do not add false fronts, false stories, or pent eaves to the roofs of commercial buildings.

SF21 Do not use storefront design elements that are historically inappropriate, such as small-pane windows or colonial doors on late 19th and 20th century buildings.

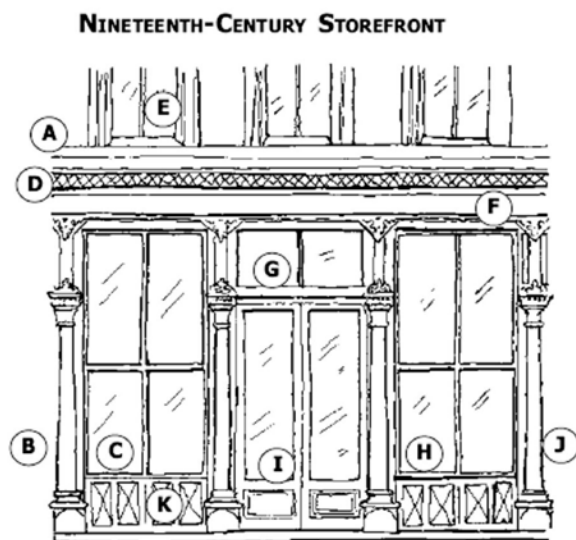

STOREFRONT ELEMENTS

- A. Upper Facade
- B. Lower Facade
- C. Storefront
- D. Cornice
- E. Upper-Floor Window
- F. Sign Band
- G. Transom
- H. Display Window
- I. Entry
- J. Piers
- K. Bulkhead

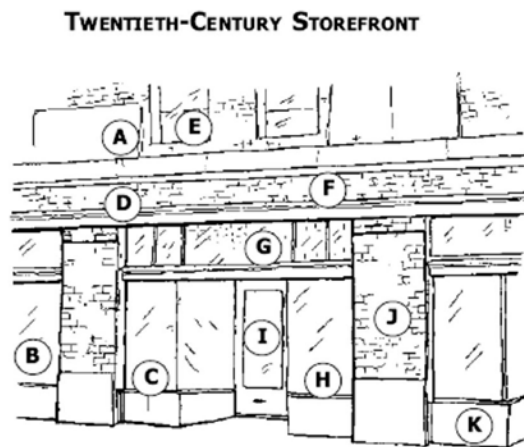

(Courtesy of Metro Historic Landmarks Commission)

SF22 Do not use materials in storefront renovations that were not available at the time of original construction, such as vinyl or aluminum siding, stainless steel, uncoated anodized aluminum, tinted glass, or artificial stone.

SF23 Use historic materials when replacement of bulkheads is required in part or in whole. Wood or stone panels are most appropriate.

SF24 Do not use rough-textured wood siding or simulated masonry, such as permastone, on storefronts.

SF25 Use historic materials when cornice replacement is required in part or in whole. Cast iron, wood, or sheet metal are appropriate materials.

SF26 Do not install inappropriately scaled signs that obscure or damage surviving storefront features that convey a building's architectural character.

SF27 Include the following storefront elements when redesigning or renovating a historic storefront: large display windows and doors, transoms, relatively thin framing elements, a cornice element separating the storefront from the upper facade, low bulkheads, and tile entry flooring.

SF28 Photographically document architectural features that are slated for reconstruction prior to the removal of any historic fabric.



Original or historic display windows such as those at 122 North Third Street should be preserved and maintained.

ALTERATIONS DISGUISE CHARACTER

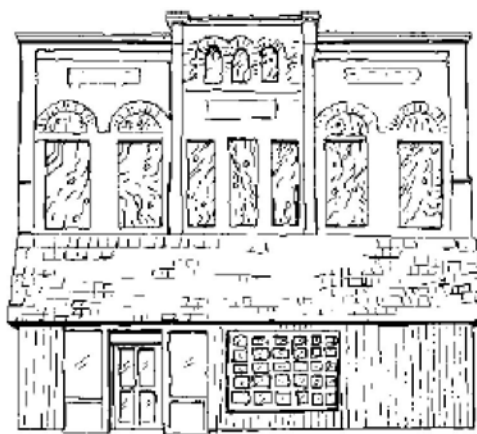

Selective removal of later, inappropriate additions, such as those seen above, and replacement with historically-compatible materials can do much to revitalize storefronts.

(Courtesy of Metro Historic Landmarks Commission)

EMPHASIZE TRANSPARENCY



Historically, storefronts used expansive plate-glass windows to advertise goods to passersby.



Inappropriate infill reduces a storefront's transparency, diminishing its historic character.

(Courtesy of Metro Historic Landmarks Commission)



This bulkhead at 125 North Third Street is covered with Carrara glass.



The building at 116 North Third Street has a Luxfer glass transom.

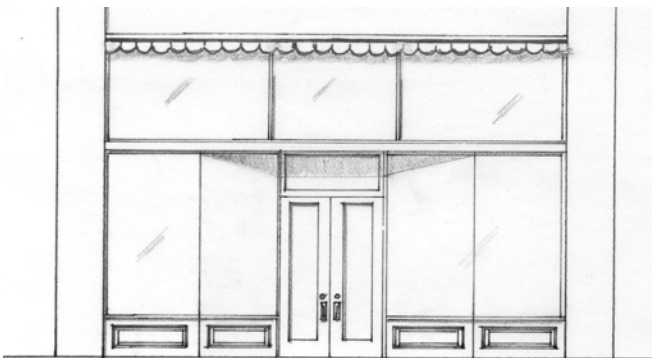

206 North Third Street's transom is recessed and has multi-pane plate-glass installed.

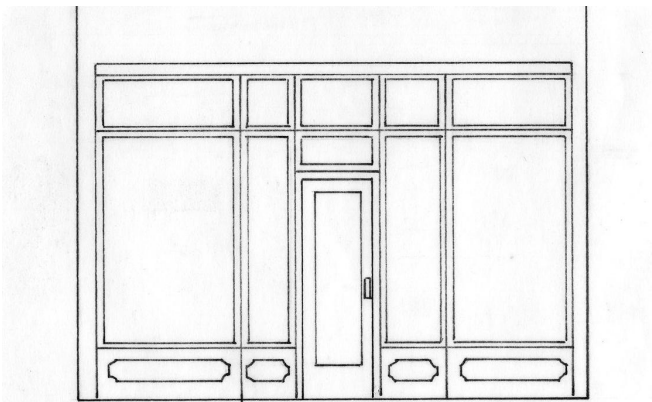

Replacement storefronts should include traditional elements; these designs are appropriate models for replacement storefronts.



Some storefronts, like the one at 229 North Third Street, have their own cornices and sign panels.

STREETSCAPES

Brick and concrete sidewalks and driveways are used in the residential and commercial sections of Bardstown's historic district. These materials should be regularly maintained and replaced with matching materials.



100 block of North Third Street

SS1 Retain historic sidewalks, driveways, and component elements.

SS2 Repair historic sidewalks, driveways, and component elements.

SS3 Construct replacement sidewalks of brick or concrete in keeping with the original historic sidewalk patterns.

SS4 Construct driveways and component elements of historically used materials like concrete, bricks, or, for driveways, gravel or dirt. The use of asphalt for driveways is discouraged but acceptable.

SS5 Construct new sidewalks and driveways in historically appropriate locations. For commercial sidewalks, this is flush with both the building façade and the street.

SS6 Maintain original curbing whenever possible. Any replacement should use historic materials. If replacement with original materials is not technically or economically feasible, a substitute material may be used if it duplicates the color, texture, and visual appearance of the original.

SS7 Restore and reuse historic paving materials, such as brick and hexagonal pavers and limestone curbing, whenever possible.

SS8 Retain historic circulation patterns, gateways, entrances, artwork, and street furniture, wherever they are character-defining features, especially in pedestrian courts.

SS9 Limit the installation of street furniture, such as street lights, garbage cans, bus shelters, telephone booths, and kiosks, to avoid overly-cluttered streetscapes. Street furniture should be durable, easy to maintain, and of a simple traditional design that is not falsely historical. If reproduction fixtures are desired for elements such as benches and streetlights, their design should be based upon historic precedent as established by photographic or pictorial evidence.

SS10 Do not carry out excavations or regarding adjacent to a historic building or site, which could cause the foundation to shift or destroy significant archeological resources.

SS11 Use understated fixtures when installing any type of exterior lighting. Fixtures should not become a focal point.

SS12 Use high-pressure sodium or metal-halide lights to create a soft illumination where site or streetscape lighting is desired.

SS13 Retain streetscape elements, such as benches, trash receptacles, planters, ash trays, and lighting fixtures, that create pleasant public spaces if well designed. These elements must be compatible in size, scale, color, and design with the viewscape of the historic commercial district.

SS14 Retain street trees to define the streetscape unless they pose a safety hazard. Removal of trees within or immediately adjacent to a

public right of way or within public open spaces requires review unless directed by the city arborist in cases of emergency or for other reasons of public safety.

SS15 Preserve large trees whenever possible. Removal of trees within or immediately adjacent to a public right of way or within public open spaces requires review unless directed by the city arborist for emergency or public safety reasons.

SS16 Enhance established street tree patterns by planting additional trees along public rights-of way and on private property. Select native deciduous species as canopy trees or trees appropriate to the period and character of the district. Consult with the city forester to determine what tree species are suitable for placement near overhead wires. Select and place street trees so that the plantings will not obscure historic storefronts once mature

SS17 Take the health and shape of trees into account when pruning. Overpruning should be avoided.

SS18 Install public utility lines underground whenever possible.



In commercial areas like the 100 block of North Third Street, new sidewalks should maintain traditional placement and materials.

STREETSCAPE IMPROVEMENTS

If carefully chosen, improvements like paving, street furniture, and plantings can substantially enhance the public's experience of a streetscape.

INVITING STREETSCAPE



UNINVITING STREETSCAPE



(Courtesy of Metro Historic Landmarks Commission)

WINDOWS

Windows dominate commercial upper facades and help create the internal rhythm of buildings. Historic windows and openings should be retained, remain uncovered, repaired as needed, and, if repair is not possible, replaced with historically appropriate replacements.



116 North Third Street

W1 Retain historic windows.

W2 Repair historic windows using materials that match the original.

W3 Replace severely deteriorated historic windows with new windows that convey the same visual appearance. Replacement windows may either be accurate reproductions using historical, pictorial, and physical documentation or be a new design that is compatible with the historic character of the building and the district. Use of vinyl- and aluminum-clad wood window systems on primary elevations may be permissible if the proportion and detail closely match the original.

W4 Select windows that match the historic sash dimension, muntin configuration, reveal depths, glass-to-frame ratios, glazing patterns, frame dimensions, trim profiles, and decorative features when repair of original windows is impossible.

W5 Evaluate the option of using appropriate salvage materials when replacing windows that are deteriorated beyond repair.

W6 Do not use replacement sash that does not fit historic window openings. Original openings should never be blocked in to accommodate stock windows.

W7 Do not install contemporary picture, glass block, or jalousie windows in exterior window openings.

W8 Do not install synthetic replacement windows (vinyl, etc.) on facades.

W9 Install replacement windows that operate in the same way as the original windows- double-hung windows are replaced with double-hung windows, and casement windows are replaced with casement windows.

W10 Do not replace multi-pane windows that have true divided lights with thermal glazing windows that have false snap-in-or applied muntins on façades.

W11 Do not apply reflective or insulating film to window glass.

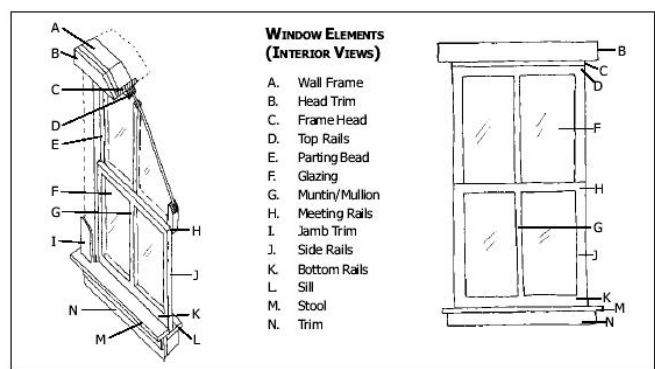

(Courtesy of Metro Historic Landmarks Commission)

W12 Do not use smoked, tinted, or reflective glass on building facades that can be seen from a public way.

W13 Use large sheets of clear glass when replacement of storefront display windows is required.

W14 Do not block in or back paint transoms or sidelights.

W15 Use surviving prototypes to reconstruct missing window elements, such as architraves, hood-molds, sash, sills, and interior or exterior shutters and blinds. The reconstructed element should be constructed of materials for which there is a historic precedent or a compatible substitute material if that is not possible.

W16 Do not alter the number, size, location, or shape of original windows seen from a public way by making new window openings or permanently blocking existing openings. If windows are no longer needed, they should be shuttered if original shutters exist. If shutters do not exist, a temporary closure should be prepared, leaving the window frame intact.

W17 Locate any new windows openings that may be required for a new use on an elevation that cannot be seen from a public way. Newly installed windows should be compatible with the overall design of the building.

W18 Do not obscure historic window trim with metal or siding materials.

W19 Do not install new floors or dropped ceilings that block the glazed area of historic windows. If such an approach is required, the design should incorporate setbacks that allow the full height of the window to be seen unobstructed.

W20 Install exterior storm windows that duplicate the shape of the original window. Storm windows should be painted to match the color of the window frame.

Arguments for Historic Windows:

- Rebuilding or adding weather stripping to historic windows makes them as efficient as new vinyl windows and more than offsets the cost of new ones.
- The old-growth lumber used in historic window frames can last indefinitely, unlike new-growth wood or vinyl.
- Vinyl window seals often fail after a few years, making their constant replacement more costly than replacing individual old panes with insulated glass or otherwise upgrading old ones.
- Vinyl windows don't look like historic wood windows; their texture and thinness is inappropriate for the district.
- Vinyl is harmful both in its creation and disposal.



Historic windows like these at 115 North Third Street should be retained and repaired.



This replacement window at 117 and 119 North Third Street is appropriate.

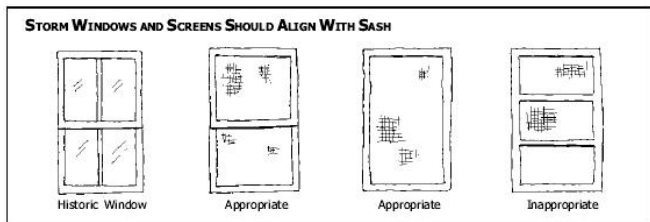

(Courtesy of Metro Historic Landmarks Commission)

SECTION 7

NON-RESIDENTIAL

NEW CONSTRUCTION

New commercial buildings should be added when historic ones are lost. These replacement buildings help maintain the historically cohesive landscape, and should use design and materials to support the district's character. Additions made to commercial buildings should be located with no or very limited public visibility, have minimal affect on the building's historic form, appearance, and materials, and be both compatible and recognizably modern.

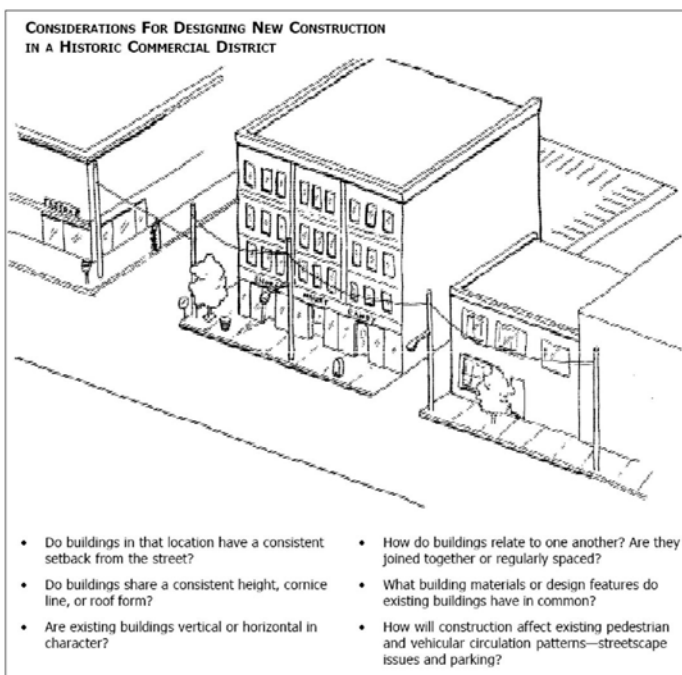

(Courtesy of Metro Historic Landmarks Commission)

NC1 Make sure that new designs conform to all other local regulations, including the Zoning Regulations, Building Code and Bardstown Municipal Code.

NC2 Do not demolish structures in a historic district to make way for new or large-scale construction, to make parking lots, or to leave vacant lots. Non-contributing buildings are identified in each of the district or individual landmark designations or National Register nominations.

NC3 Design new construction so that the building height, scale, massing, volume, directional emphasis, and setback reflects the architectural context established by surrounding

structures.

NC4 Make sure that the scale of new construction does not conflict with the historic character of the district.

NC5 Select materials and design elements for new construction that are sympathetic with surrounding historic buildings in the district. Materials should be of a complementary color, size, texture, scale, and level of craftsmanship.

NC6 Do not use materials in new construction that are visually incompatible with surrounding historic buildings within the district. Materials to be avoided include: ornamental pierced concrete masonry screens and walls, antiqued brick, wrought-iron porch columns, chain-link fencing, exterior carpeting, jalousie windows, glass block, picture windows, unpainted wood, and asphalt siding.

NC7 Have new construction reinforce the human scale of historic districts by emphasizing the base of the building where this is a character-defining feature.

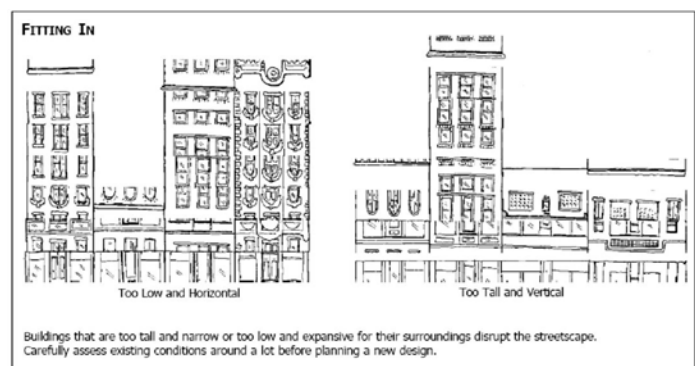

(Courtesy of Metro Historic Landmarks Commission)

NC8 Design infill construction that enhances the pedestrian-oriented character of historic commercial districts. Commercial buildings should have a well-defined base at the pedestrian level with details conveying a sense of horizontality and progression along the sidewalk.

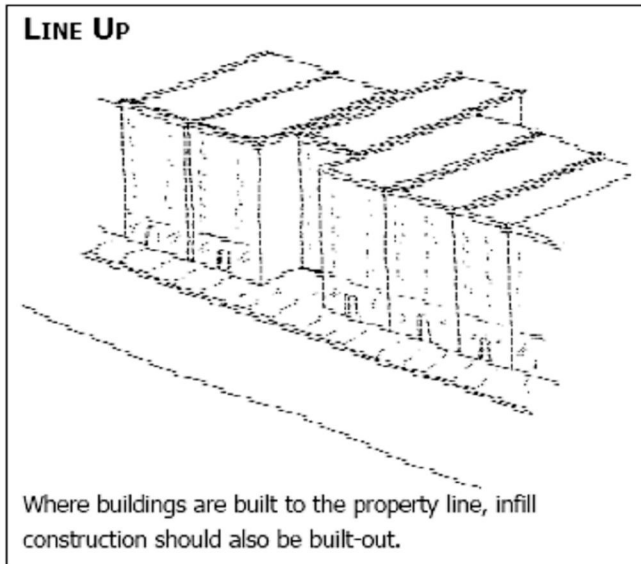

(Courtesy of Metro Historic Landmarks Commission)

NC9 Design new construction in such a way that it does not disrupt important public views and vistas.

NC10 Plant canopy trees in front of any large-scale new construction to provide a visual sense of consistency along a streetscape.

NC11 Reinforce existing patterns of open space and enclosure, created by circulation routes, fences, walls, lawns, and alleys of trees, in designs for new construction.

NC12 Design infill construction that reinforces the spatial organization established by surrounding buildings. The character of historic streetscapes relies heavily on the visual continuity established by the repetition of similarly-designed facades.

NC13 Design infill construction in such a way that the facade's organization closely relates to surrounding buildings. Window and door openings should be similar in size to their historic counterparts, as should the proportion of window to wall space. Cornice lines, columns, and storefronts are other important character-defining facade elements.

NC14 Design new construction so that the building mass has a similar sense of lightness or

weightiness as surrounding historic structures. Mass is determined by the proportion of solid surfaces (walls) to voids (window and door openings).

NC15 Maintain historic patterns of window and door proportion and placement in designs for new construction.

NC16 Develop designs for new construction using windows that are sympathetic to the window patterns of surrounding buildings. Use of comparable frame dimensions, proportions, and muntin configurations is encouraged.

NC17 Develop designs for new construction using front doors that are sympathetic to the door patterns of surrounding buildings. Use of comparable frame dimensions, proportion, and panel and light configuration is encouraged.

NC18 Design new construction so that the orientation of the main entrance is the same as the majority of other buildings on the street.

NC19 Retain the character-defining features of a historic building when undertaking accessibility code-required work.

NC20 Investigate removable or portable ramps as options to providing barrier-free access.

NC21 Locate handicapped access ramps on secondary elevations wherever possible. If locating a ramp on the primary façade is required, it should be installed in a way that does not damage historic fabric and is as unobtrusive as possible.

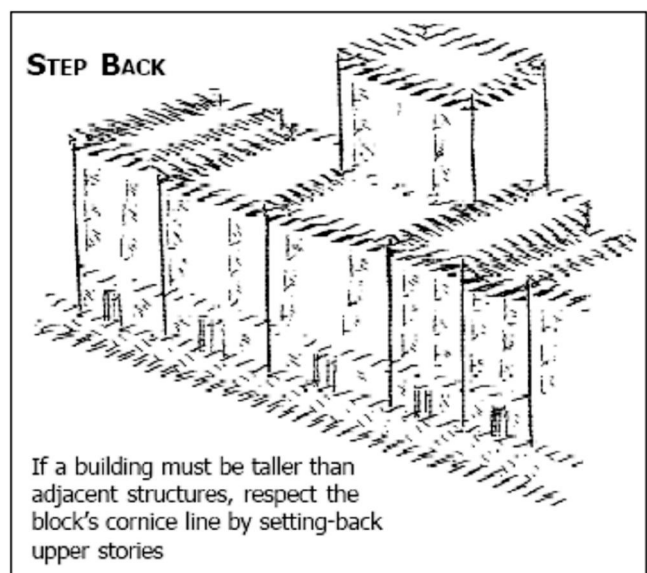

(Courtesy of Metro Historic Landmarks Commission)

NC22 Design infill construction so that it is compatible with the average height and width of surrounding buildings. The rhythm of the facade should also reflect the characteristic rhythm of existing buildings on the street. Vertical elements (doors, columns, and storefronts) should be spaced approximately every 20 to 40 feet at the pedestrian level.

NC23 Design new construction to have a floor-to-floor height that is within 10 percent of adjacent historic construction where the floor-to-floor height is relatively consistent, and a character-defining feature.

NC24 Incorporate set-back upper stories into designs for new construction that exceed the established cornice line.

NC25 Maintain the historic rhythm of the streetscape. The space between new construction and existing structures should fall within 20 percent of the average spacing for the block. New construction should be built out to the property lines where this is a character-defining feature.

NC26 Historic corner commercial properties have long been anchors in Bardstown's preservation districts. Construction of commercial properties on vacant corner lots should preferably be built to the corner with an entrance oriented to the corner.

NC27 Maintain historic setback patterns. In order to maintain the continuity of the streetscape, setbacks for new construction should either match that of adjacent buildings where all share the same setback or be within 20 percent of neighboring structures in areas with varied setbacks.

NC28 Ensure that the roofs of new buildings relate to those of neighboring historic structures in pitch, complexity, and visual appearance of materials.

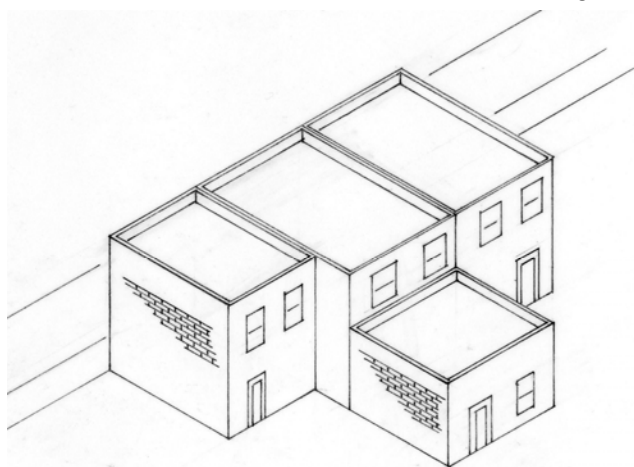

This addition is appropriately placed to connect to its building through historic openings, and it appropriately mimics the scale, proportions, and rhythm of the attached building.

PARKING CONSIDERATIONS

Historic buildings should never be demolished for parking lots.

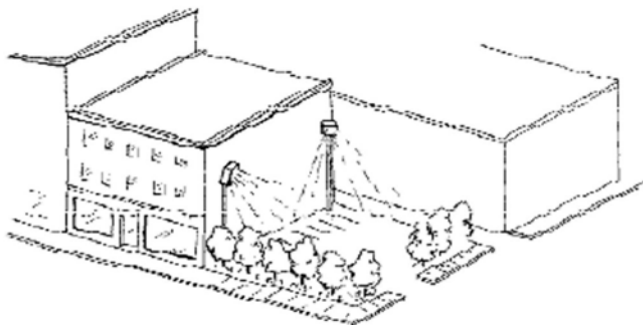

Parking lots developed on vacant land should:

- be accessed off secondary streets and alleys;
- allocate space for plantings;
- have restrained lighting; and
- include street trees, fencing, colonnades, or other elements to maintain the building line.

(Courtesy of Metro Historic Landmarks Commission)

NC29 Follow the precedent set by adjacent buildings when designing rooflines for infill construction. Where the predominate form is flat, built-up roofs are preferred. Where the predominate form is complex and steeply pitched, that is preferred. In blocks characterized by shallow-pitched roofs and pronounced overhangs with exposed rafters, these elements should be incorporated.

NC30 Design new construction so that the orientation of the main roof form is parallel with the majority of other roofs on the street where roof forms are relatively consistent and a character-defining feature.

NC31 Design new construction to emphasize the existing cornice line on each block where this is a character-defining feature.

NC32 Integrate mechanical systems into new construction in such a way that rooftops remain uncluttered.

NC33 Make provisions for screening and storage of trash receptacles when designing new construction.

NC34 Use an exterior sheathing that is similar to those of other surrounding historic buildings.

NC35 Use masonry types and mortars that are similar to surrounding buildings in designs for new construction.

NC36 Do not use modern ~~antiqued~~ brick in new construction.

NC37 Design parking garages so that they relate closely to adjacent structures. Their facades should reflect the hierarchical organization and design elements seen on surrounding buildings.

NC38 Design new construction so that access to off-street parking is off alleys or secondary streets wherever possible.

NC39 Generally, leave at least 20 percent of a parking lot's surface area unpaved and planted. All parking lots must meet the minimum requirements of the Zoning Regulations. Perimeter landscaping, fencing, colonnades, or other construction that visually continues the building line along open sidewalks is encouraged.

NC40 Generally speaking, parking should be located in the rear.

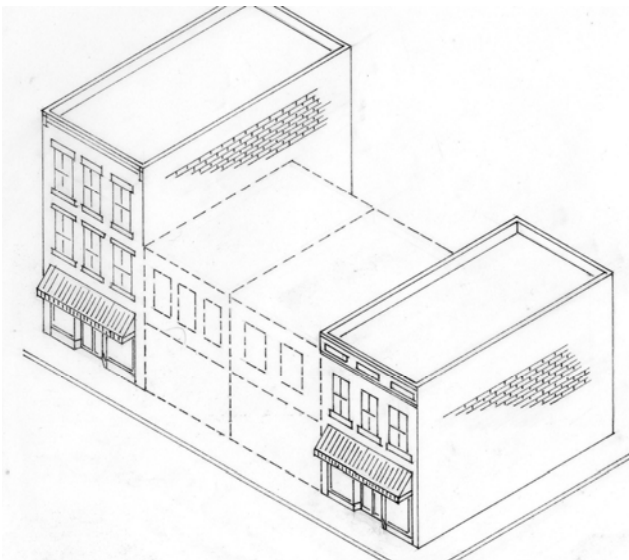

The two new commercial buildings outlined appropriately base their overall height, horizontal rhythm, vertical division, setback, and shared sidewalls on their historic neighbors.



The vertical divisions in this new building appropriately reflect the proportions established by its historic neighbors.

NC41 Design required new parking in such a way that it is as unobtrusive as possible and minimizes the impact on the historic setting. Shared parking areas among groups of businesses is encouraged.

NC42 Do not build additional surface parking lots within the Historic District.

NC43 Incorporate storm-water management provisions into the design of new construction, so that any related runoff will not adversely impact nearby historic resources.

NC44 Do not create additional open space within the Historic District.



The location of the addition at 103 North Third Street, along the rear elevation, is appropriate.



The new buildings outlined above are inappropriate because of their lack of regular spacing and proportions of the upper windows and storefronts.



These outlined new buildings are consistent with the types of window and storefront openings present along the street.

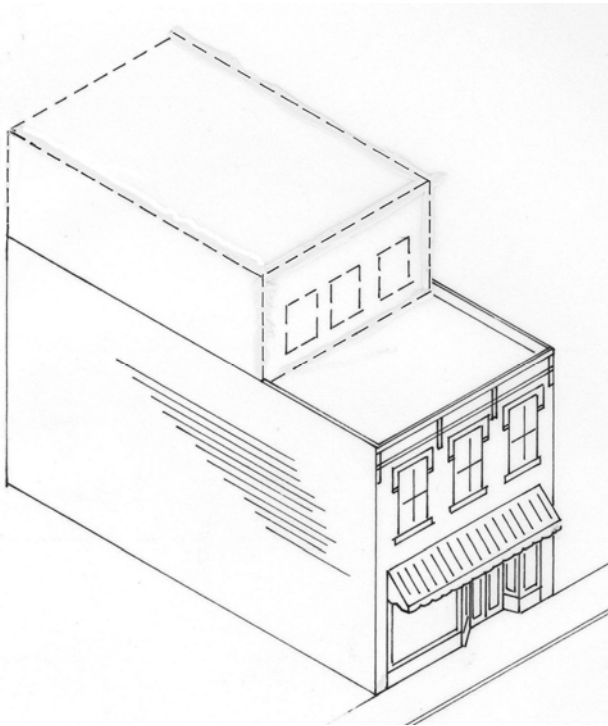

Rooftop additions like those shown here should be set back from the historic façade so as not to be visible from the street.



These new townhouses at 211-215 North Third Street use appropriate form and scale. (NCPZ Digital Archive)



Brick, used here at 222 North Second Street, is an appropriate material for new construction. (NCPZ Digital Archive)



This contemporary corner building at 202 West Stephen Foster is an appropriate model for new commercial construction in Bardstown. (NCPZ Digital Archive)

SECTION 8

ECONOMIC HARDSHIP EXEMPTION

Historic buildings, for one reason or another, present particular challenges for rehabilitation, adaptive reuse, and sometimes even continued habitation. All buildings require proper maintenance, and older buildings are particularly susceptible to deterioration. In the absence of a good roof or a few windows, the elements can do irreparable damage within a surprisingly short period of time. Abandoned buildings are particularly subject to rapid deterioration and may attract vagrants or vandals who will, intentionally or not, accelerate the deterioration. The best way to prevent demolition is to keep buildings properly maintained and secured. But it is an unhappy reality that occasionally buildings deteriorate to the point that demolition becomes a consideration.

When an application for demolition is submitted, Bardstown Historic Review Board shall study the question of economic hardship. The procedure for determining economic hardship is rigorous, and the standards set for determining what constitutes economic hardship are quite high. The test for economic hardship is not whether demolition provides a better use or return, but whether denial of the owner's request to demolish deprives the owner of *any reasonable beneficial use* in the case of a non-income producing property, or *any reasonable return* in the case of an income-producing property. The burden of proof is on the property owner to prove that any reasonable beneficial use (in the case of non-income producing property) or any reasonable return (for income producing property) cannot be obtained without the proposed demolition and/or new construction.

The most important criteria for reviewing applications for demolition of an existing structure within any local historic district or any individual landmark is: *unless the City has determined that a structure poses an imminent threat to life or property, as set forth in Section 15.9 of the Zoning Regulations, no application shall be approved to demolish any structure unless:*

1. The demolition will not adversely affect the district's (or the landmark's) distinctive characteristics, taken as a whole, retained over time;
2. The demolition will not adversely affect the district's importance as a unified entity+composed of interrelated resources united historically or aesthetically by plan or physical development; and
3. The proposed plan for development of the site, including structures, landscaping, and lighting, will strengthen the viability of the district as a whole or for the landmark site.

Determining Economic Hardship

A procedure has been established for evaluating whether or not the historic preservation ordinance and guidelines for demolition and/or new construction constitute an economic hardship for individual property owners. The process is intended to give fair review and consideration to the possibility that a property owner may have a claim to being exempt from specific historic preservation guidelines pertaining to demolition. The request for economic hardship exemption must be initiated at the time the application for demolition is filed.

The process is fair but requires the property owner to provide substantial proof that he or she deserves an exemption due to economic hardship. The rationale for this kind of inflexible regulation is that local historic districts are subject to seemingly small losses and degradation that will, over time, amount to significant and irreversible damage to the integrity and character of the historic districts and landmarks. This strict guideline recognizes and protects the significance of every one of Bardstown's historic buildings. The process to apply for an economic hardship exemption begins when the property owner ap-

plies to the Bardstown Historical Review Board for a Certificate of Appropriateness. The property owner must, *upon submission of the application for the Certificate of Appropriateness*, submit evidence and documentation establishing that compliance with a specific design guideline or guidelines will constitute economic hardship. It is thus attendant upon the property owner to anticipate when he or she may require an economic hardship exemption from one or more of the guidelines for demolition. The property owner should consult with the Historical Review Board staff, if he or she suspects the project will require an economic hardship exemption. The documentation and evidence that will be required for the determination of economic hardship is discussed below.

The Historical Review Board shall hold a public hearing within 30 days on the application for a Certificate of Appropriateness for demolition and will consider the evidence and documentation on the request for demolition and economic hardship exemption.

Within 60 days of the request, the Historical Review Board shall take final action on the request. If the Historical Review Board approves the request for demolition, the Historical Review Board will issue a Certificate of Appropriateness. If the Historical Review Board denies the request for demolition, the Applicant may appeal to the Bardstown City Council, and the Bardstown City Council shall hold a public hearing within 45 days after the notice of appeal is filed. If the Bardstown City Council overturns the demolition, then it will transmit its decision to the Administrative Officer and a demolition permit shall be approved and issued. If the Bardstown City Council concurs with the Historical Review Board's denial, then the Applicant may appeal to Nelson County Circuit Court.

Evidence and Documentation of Economic Hardship

Hardship determinations focus on the structures and not the owners' personal financial circumstances. The Bardstown Historical Review Board is charged with undertaking a detailed review of the facts associated with building projects that have the potential to have significant negative effect upon the character of Bardstown's historic districts and individual landmarks. In order to make informed and fair evaluations of specific proposals, the Board will require detailed economic information pertaining to the finances of the historic structure as well as the use to which it will be put.

In order to be granted the hardship exemption that would clear the way for demolition of an **income-producing** historic structure, the Applicant must provide clear and convincing evidence that any reasonable return cannot be obtained from the property or structure without approval of the request for demolition or for new construction. In order to show that any reasonable return cannot be obtained, the applicant must show that:

1. The property or structure currently is not capable of providing any reasonable return; and
2. *Bona fide* efforts to sell or lease the property or structure have been fruitless; and
3. The costs required to rehabilitate the property or structure are such that any reasonable return on such an investment is not achievable.

In order to be granted the hardship exemption that would clear the way for demolition of a historic structure that is **non-income producing** (e.g., owner-occupied residences) or for new construction, the applicant must demonstrate through a preponderance of the evidence that the property or structure cannot be put to any reasonable beneficial use without approval of the request for demolition or for new construction. In order to show that beneficial use of the property or structure cannot be obtained, the applicant must show that:

1. The property or structure cannot now be put to any beneficial use; and
2. *Bona fide* efforts to sell or lease the property or structure have been fruitless; and
3. It is not economically feasible to rehabilitate the property or structure.

In order to meet the tests for income and non-income producing property, an applicant seeking an economic hardship exemption must provide the following information pertaining to the historic structure.

A. Financial Information

1. Form of ownership of the property, whether by sole proprietorship, for-profit, or not-for-profit corporation, limited partnership, joint venture, etc.;
2. Most recent PVA assessments;
3. Remaining balance on any bonafide mortgage or other financing secured by the property and annual debt source, if any, for the previous two years;
4. Purchase price, date, and seller, including relationship, if any;
5. Copy of current deed;
6. Current assessed value of land and improvements;
7. Annual gross income of property, if applicable;
8. Operating and maintenance expenses;
9. Real estate taxes, if applicable;
10. Annual cash flow from property;
11. Other federal income tax deductions produced, if applicable;
12. Any and all appraisals;
13. All listings for sale or rent in the past two years;
14. Prices asked and offers received, including broker's testimony
15. Profitable and adaptive reuses considered, as applicable; and,
16. Tax returns on or relating to property.

B. Determination of Reasonable Return/Feasibility of Beneficial Uses

1. Estimated cost of demolition and estimated current market value of the property after completion of proposed demolition;
2. Report from licensed architect or engineer regarding condition of structure;
3. Identification of alternative uses;
4. Cost estimates associated with rehabilitation for reasonable uses, including the scope of work upon which the cost estimate is based;
5. Pro forma of projected revenue and expenses for use or reuse of existing improvements, including the use of any tax credits, if applicable;
6. Estimate of current market value of property, with land and existing improvements as is;
7. Estimate of Internal rate of return based upon pro forma of income and expenses, including tax credits and estimate of equity investment, if applicable;
8. Estimates and analysis of the net impact of proposed new construction in stabilizing property values and the integrity of the district as a whole or of the local landmark; and,
9. Such other information as the Commission may reasonably request.

Demolition by Neglect

The deteriorated condition of a historic building attributable to the owner's failure to provide proper maintenance over an extended period of time will not be considered a mitigating circumstance in evaluations of economic hardship. Hardship that is attributable to a building's being allowed to deteriorate will be considered self-imposed; restoration costs incurred to remediate such neglect will not be considered.

SECTION 9

DEMOLITION

The best way to prevent demolition is to keep buildings properly maintained and secured. Demolition is the most drastic building treatment possible. It irreversibly removes a component of Bardstown's historic landscape, and should take place only when no other option for building treatment is available. The guidelines for demolition are particularly stringent, because the repeated loss of historic resources results eventually in irreversible damage to the integrity and character of the historic district. Demolition will not be approved until plans for new construction or development for the site have also been reviewed.

D1 Maintain historic properties by providing ordinary maintenance and repair.

D2 Do not demolish a structure until the City has determined that it poses an immediate threat to life or property, or a Certificate of Appropriateness allowing demolition has been approved.

D3 Unless the City has determined that a structure poses an imminent threat to life or property, as set forth in Article 15.7 of the Zoning Regulations, no application shall be approved to demolish any historic structure or part of an historic structure within a local historic district or any individual landmark unless:

1. The demolition will not adversely affect the district's (or the landmark's) distinctive characteristics, taken as a whole, retained over time;
2. The demolition will not adversely affect the district's importance as a unified entity composed of interrelated resources unified historically or aesthetically by plan or physical development

D4 Upon approval of an application to demolish, do not demolish non-historic buildings and additions in a manner that will threaten the integrity of existing historic structures.

D5 Upon approval of an application to demolish, do take steps to assure the integrity of a wall exposed to the elements by the removal of a non-historic addition.

D6 Upon approval of an application to demolish, do remove non-historic interior finishes such as plaster, drywall, or paneling that may be exposed as a result of the removal of non-historic additions.

D7 Upon approval of an application to demolish, do infill non-historic openings in historic wall, exposed as a result of the removal of the non-historic finishes.

D8 Do landscape areas that are left vacant as the result of removals of non-historic buildings and additions. Topography should be made consistent with that of adjacent properties. The slope and grades of land left vacant after demolition should continue and be consistent with those features on adjacent properties.

D9 Upon approval of an application to demolish, do take measures to reestablish the street wall after demolition through the use of low fences, walls, and/or vegetation.

SECTION 10

CONDITIONAL USE

To encourage the adaptive use but discourage inappropriate rezonings of local historic district properties or local landmark and landmark sites, a conditional use permit may be issued for any use otherwise allowed in any zoning classification. For example, the property at 106 East Broadway Avenue is a residential property within the local historic district and zoned R-1C (Single-Family Residential District) but is used as a professional law office. Although professional offices are otherwise not allowed as permitted or conditional uses in the R-1C zoning district, the Bardstown Historical Review Board recommended approval and the Bardstown Board of Adjustment approved a conditional use permit for the professional law office to allow the adaptive use of the property and to prevent commercial encroachment into the historic residential neighborhood.

As defined by Kentucky Revised Statutes 100.111(6), a conditional use is "a use which is essential to or would promote the public health, safety, or welfare in one (1) or more zones, but which would impair the integrity and character of the zone in which it is located, or in adjoining zones, unless restrictions on location, size, extent, and character of performance are imposed in addition to those imposed in the zoning regulation."

A conditional use permit is legal authorization to undertake a conditional use, issued by the administrative official pursuant to authorization by the Board of Adjustment (BOA), consisting of two parts: (1) A statement of the factual determination by the BOA that justifies the issuance of the permit, and, (2) A statement of the specific conditions that must be met in order for the use to be permitted.

During their review of a conditional use permit application, the Historical Review Board must consider if the proposed conditional use complies with the following mandatory requirements:

1. The area, structure, or premises are situated in its entirety within the local historic district or on the local landmark site where the local landmark is located;
2. The physical conditions are unique in that the premises or structures area of aesthetic architectural or historical significance and worthy of preservation;
3. The conditional use considered, exclusive of all other considerations, will provide for the preservation and/or restoration of the historic resource;
4. The Owner consents, in writing, to maintain and/or instigate restoration and thereafter maintain the premises consistent with the original area and/or structural design and to any other conditions as may be imposed by the Historical Review Board; and,
5. The proposed use does not constitute an unreasonable use of the premises or unreasonably abridge the intent of the Zoning Regulations and will not be detrimental to any neighboring premises.

If recommended by the Historical Review Board, the conditional use permit is then forwarded to the Bardstown Board of Adjustment for their consideration and final action.

Conditional use permits are reviewed annually to ensure compliance with the mandatory requirements and other conditions of approval.



This former residence at 106 East Broadway Avenue is now used as a law office.

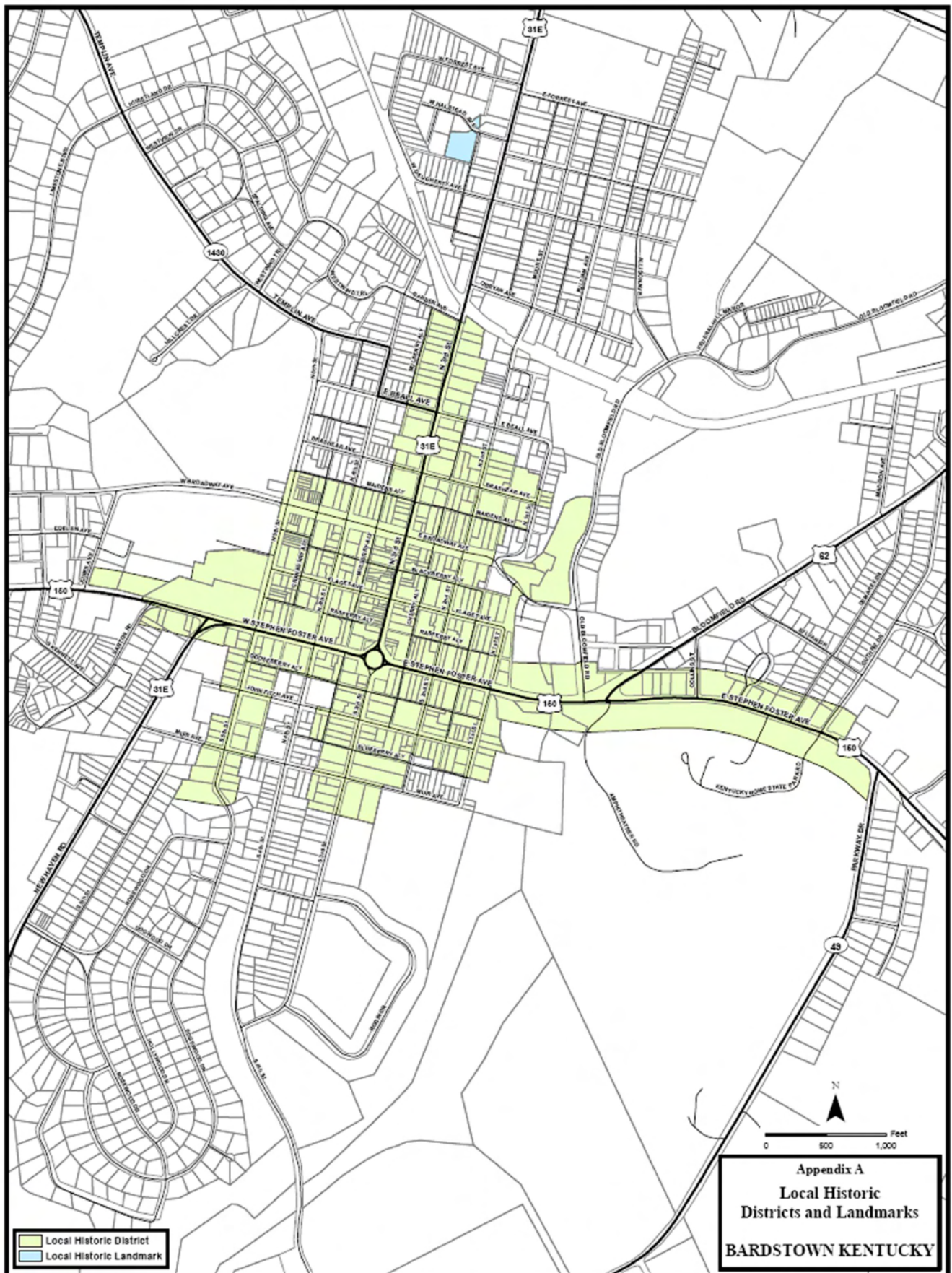

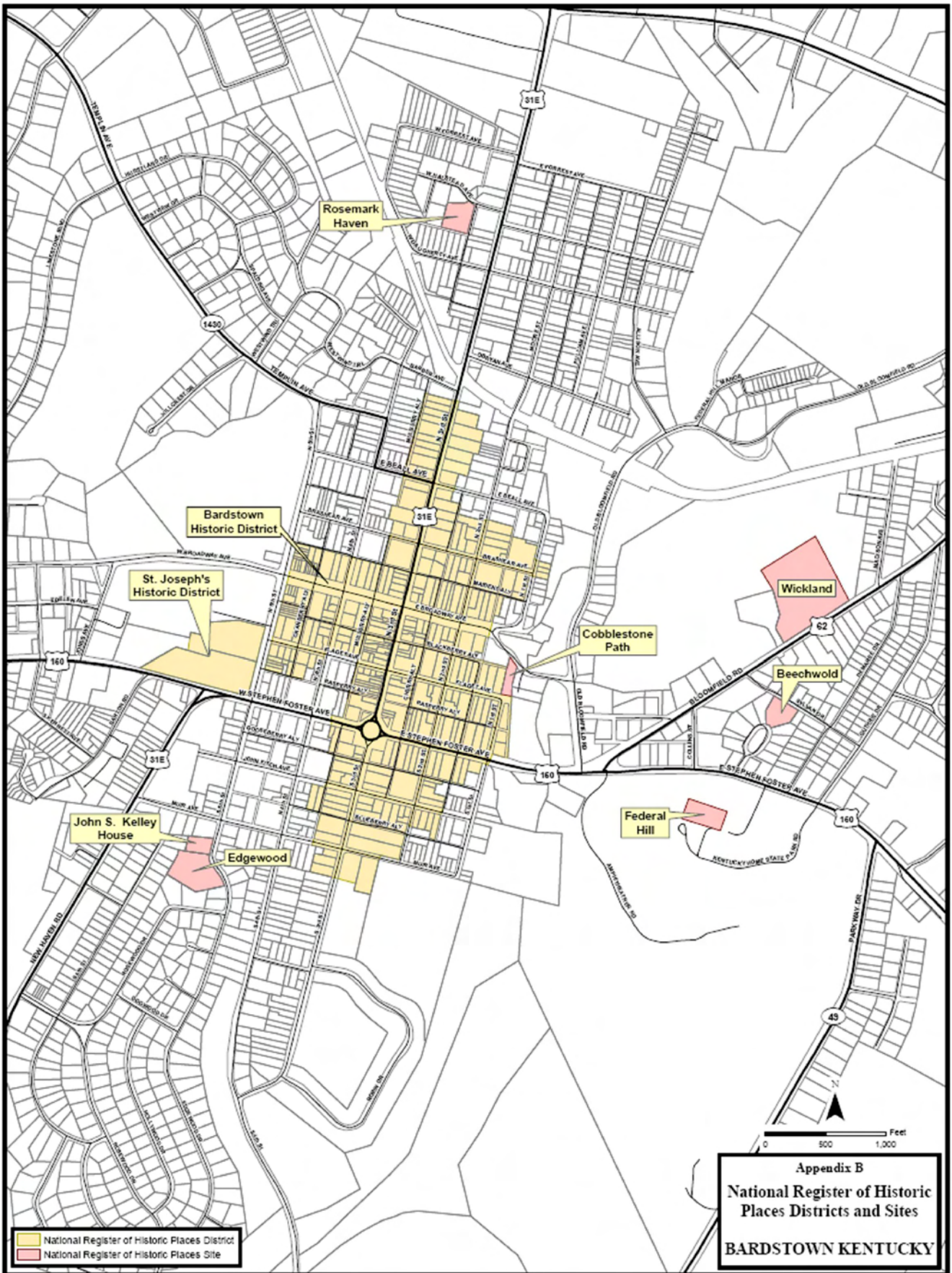

APPENDIX C

DEFINITIONS

PROCEDURAL DEFINITIONS

Certificate of Appropriateness (COA) A document awarded by a preservation commission allowing an applicant to proceed with a proposed alteration, demolition, or new construction in a designated area or site, following a determination of the proposal's suitability according to applicable criteria.

Certified Local Government Any city, county, parish, township, municipality, or borough or any other general purpose subdivision which may participate in the activities outlined in the National Preservation Act Amendments of 1980 to further delegate responsibilities and funding to the local level.

Due process The established procedure by which legal action is carried out.

Economic Hardship A case where the denial of a Certificate of Appropriateness application would result in a denial of reasonable beneficial use of the property. It does not refer to the economic status of the property owner.

Public notice The classified advertisement of an event, such as a preservation commission meeting, that is published in the local newspaper and posted in the city government building in order to notify the general public of the upcoming event.

TECHNICAL DEFINITIONS

Addition New construction added to an existing building or structure.

Alteration Work which impacts any exterior architectural feature including construction, reconstruction, repair, or removal of any building element.

Appropriate Compatible with the historic context.

Appurtenances The visible, functional objects accessory to and part of buildings.

Building A structure used to house human activity such as a dwelling or garage.

Character The qualities and attributes of any structure, site, street or district.

Compatible In harmony with location and surroundings.

Configuration The arrangement of elements and details on a building or structure which help to define its character.

Contemporary Reflecting characteristics of the current period. Contemporary denotes characteristics which illustrate that a building, structure, or detail was constructed in the recent past rather than being imitative or reflective of a historic design.

Context The setting in which a historic element, site, structure, street, or district exists.

Contributing Building, Site, or Structure A property within a historic district that is historically significant through association with historic events or activities, association with important persons, distinctive design or physical characteristics, or potential to provide important information about prehistory or history and possesses integrity by possessing historic qualities including location, design, setting, materials, workmanship, feeling, and association.

Demolition Any act which destroys in whole or in part a building or structure.

Demolition by Neglect The destruction of a building or structure through abandonment or lack of maintenance.

Design Guidelines Criteria developed by preservation commissions to identify design concerns in an area and to help property owners ensure that rehabilitation and new construction respect the character of designated buildings and districts.

Element A material part or detail of a site, structure, street, or district.

Elevation Any one of the external faces of a building.

Fabric The physical material of a building, structure, or community, connoting an interweaving of component parts.

Harmony Pleasing or congruent arrangement.

Height The distance from the bottom to the top of a building or structure.

Historic District A geographically definable area with a significant concentration of buildings, structures, sites, spaces, or objects unified by past events, physical development, and design, setting, materials, workmanship, sense of cohesiveness or related historical and aesthetic associations. The significance of a district may be recognized through listing in a local, state, or national landmarks register and may be protected legally through enactment of a local historic district ordinance administered by a historic district board or commission.

Historic Imitation New construction or rehabilitation where elements or components mimic an architectural style but are not of the same historic period as the existing buildings.

Infill New construction in historic districts on vacant lots or to replace existing buildings.

Landmark A resource with significance in history, archaeology, architecture, or culture which retains enough integrity of site, setting, location, design, materials, and workmanship to convey that history to a modern viewer.

Landmark Site A location possessing historic, cultural, or archaeological value regardless of the value of any existing structure.

Landscape The totality of the built or human-influenced habitat experienced at any one place. Dominant features are topography, plant cover, buildings, or other structures and their patterns.

Local Historic District A local historic district is a defined geographic area that has historical, architectural, social, or geographical significance to the community. The designation of the district as an overlay historic district is formal recognition of the district's significance and importance for protecting the district through local preservation ordinance and design guidelines.

Local Historic Site A building, structure, object or site which is identified as a historic resource of particular significance.

Maintain To keep in an existing state of preservation or repair.

New Construction Construction that is characterized by the introduction of new elements, sites, buildings, or structures or additions to existing buildings and structures in historic areas and districts.

Non-Contributing Building, Site or Structure A property within a historic district that lacks historical significance through association with historic events or activities, association with important persons, distinctive design or physical characteristics, or potential to provide important information about prehistory or history and/or does not possess integrity by possessing historic qualities including location, design, setting, materials, workmanship, feeling, and association.

Obscured Covered, concealed, or hidden from view.

Preservation Generally, saving from destruction or deterioration old and historic buildings, sites, structures, and objects and providing for their continued use by means of restoration, rehabilitation, or adaptive use.

Proportion Harmonious relation of parts to one another or to the whole.

Recommendation An action or activity advised but not required by the Historic Preservation Board.

Reconstruction The act or process of reproducing by new construction the exact form and detail of a vanished building, structure, or object, or a part thereof, as it appeared at a specific period of time.

Rehabilitation The act or process of returning a property or building to usable condition through repair, alteration, and/or preservation of its features which are significant to its historical, architectural, and cultural values.

Restoration The act or process of accurately taking a building's appearance back to a specific period of time by removing later work and by replacing missing earlier features to match the original.

Retain To keep secure and intact. In the guidelines, "retain" and "maintain" describe the act of keep-

ing an element, detail, or structure and continuing the same level of repair to aid in the preservation of elements, sites and structures.

Reuse To use again. An element, detail, or structure might be reused in historic districts.

Rhythm Movement or fluctuation marked by the regular occurrence or natural flow of related elements.

Scale Proportional elements that demonstrate the size, materials, and style of buildings.

Setting The sum of attributes of a locality, neighborhood, or property that defines its character.

Significant Having particularly important associations within the contexts of architecture, history, or culture.

Stabilization The act or process of applying measures essential to the maintenance of a deteriorated building as it exists at present, establishing structural stability and a weather-resistant enclosure.

Streetscape The distinguishing character of a particular street as created by its width, degree of curvature, paving materials, design of the street furniture, and forms of surrounding buildings.

Style A type of architecture distinguished by special characteristics of structure and ornament and often related in time; also a general quality of a distinctive character.

ARCHITECTURAL TERMS

Apron A decorative, horizontal trim piece on the lower portion of an architectural element.

Arch A curved construction of wedge-shaped stones or bricks which spans an opening and supports the weight above it. (see flat arch, jack arch, segmental arch and semi-circular arch)

Architrave The lowest section of the entablature that rests on the capital of a column. It also refers to the decorative molding around a door or window.

Attic The upper level of a building, not of full ceiling height, directly beneath the roof.

Baluster One of a series of short, vertical, often vase-shaped members used to support a stair or porch handrail, forming a balustrade.

Balustrade An entire rail system with top rail and balusters.

Bargeboard A board which hangs from the projecting end of a gable roof, covering the end rafters, and often sawn into a decorative pattern. Also called a vergeboard.

Battered Having sloped sides, in reference to piers and columns in the bungalow style.

Bay The portion of a facade between columns or piers providing regular divisions and usually marked by windows.

Bay window A projecting window that forms an extension to the floor space of the internal rooms; usually extends to the ground level.

Belt course A horizontal band usually marking the floor levels on the exterior facade of a building.

Board and batten Siding fashioned of boards set vertically and covered where their edges join by narrow strips called battens.

Bond A term used to describe the various patterns in which brick or stone is laid, see: "common bond," "English bond," "Flemish bond," "running bond," and "stack bond."

Brace An essential structural member placed diagonally as a support between horizontal and vertical surfaces, as under the eaves of a roof.

Bracket A projecting element of wood, stone or metal which spans between horizontal and vertical surfaces (eaves, shelves, overhangs) as decorative support.

Canopy A projecting awning suspended above an opening.

Capital The head of a column or pilaster.

Casement window A window with one or two sashes which are hinged at the sides and usually open outward.

Clapboards Horizontal wooden boards, thinner at the top edge, which are overlapped to provide a weatherproof exterior wall surface.

Classical order Derived from Greek and Roman architecture, a column with its base, shaft, capital and entablature having standardized details and proportions, according to one of the five canonized modes: Doric, Tuscan, Ionic, Corinthian, or Composite.

Clipped gable A gable roof where the ends of the ridge are terminated in a small, diagonal roof surface.

Column A circular or square vertical structural member.

Common bond Brickwork pattern where most courses are laid flat, with the long "stretcher" edge exposed, but every fifth to eighth course is laid perpendicularly with the small "header" end exposed, to structurally tie the wall together.

Corbel In masonry, a projection, or one of a series of projections, each stepped progressively farther forward with height and articulating a cornice or supporting an overhanging member.

Corinthian order Most ornate classical order characterized by a capital with ornamental acanthus leaves and curled fern shoots.

Cornice The uppermost, projecting part of an entablature, or feature resembling it. Any projecting ornamental molding along the top of a wall, building, etc.

Cresting A decorated ornamental finish along the top of a wall or roof, often made of ornamental metal.

Cross-gable A secondary gable roof which meets the primary roof at right angles.

Cupola Adorned roof set on a circular base, often set on the ridge of a roof.

Dentils A row of small tooth-like blocks in a classical cornice.

Doric order A classical order with simple, unadorned capitals, and with no base.

Dormer A small window with its own roof that projects from a sloping roof.

Dormer window A window that projects from a roof.

Double-hung window A window with two sashes, one sliding vertically over the other.

EFIS Stands for Exterior Finish and Insulating Systems and is a synthetic form up stucco. A common brand is Dryvit.

Eave The edge of a roof that projects beyond the face of a wall.

Elevation Any of the external faces of a building.

Ell The rear wing of a house, generally one room wide and running perpendicular to the principal building.

Engaged column A round column attached to a wall.

Entablature A part of a building of classical order resting on the column capital; consists of an architrave, frieze, and cornice.

Facade The face or front elevation of a building.

Fanlight A semi-circular window usually over a door with radiating muntins suggesting a fan.

Fascia A projecting flat horizontal member or molding; forms the trim of a flat roof or a pitched roof; also part of a classical entablature.

Fenestration The arrangement of windows on a building.

Finial A projecting decorative element, usually of metal, at the top of a roof turret or gable.

Fish-scale shingles A decorative pattern of wall shingles composed of staggered horizontal rows of wooden shingles with half-round ends.

Flashing Thin metal sheets used to prevent moisture infiltration at joints of roof planes and between the roof and vertical surfaces.

Flat arch An arch whose wedge-shaped stones or bricks are set in a straight horizontal line. Also

called a jack arch.

Flemish bond A brickwork pattern where the long "stretcher" edge of the brick is alternated with the small "header" end for decorative as well as structural effectiveness.

Fluting Shallow, concave grooves running vertically on the shaft of a column, pilaster, or other surface.

Foundation The lowest portion of the building wall, which supports the structure above.

Fretwork Ornamental woodwork, cut into a pattern, often elaborate.

Frieze The middle portion of a classical cornice; also applied decorative elements on an entablature or parapet wall.

Frieze Board Flat board at top of wall directly beneath the cornice.

Gable The triangular section of a wall to carry a pitched roof.

Gable roof A pitched roof with one downward slope on either side of a central, horizontal ridge.

Gambrel roof A ridged roof with two symmetric slopes on either side.

Gingerbread Pierced curvilinear ornament made with a jig or scroll saw.

HVAC Heating, ventilation, and air conditioning

Hipped roof A roof with uniform slopes on all sides. (All eaves are at the same level)

Hood molding A projecting molding above an arch, doorway, or window, originally designed to direct water away from the opening; also called a drip mold.

Ionic order One of the five classical orders used to describe decorative scroll capitals.

Infill New construction where there had been open space before, such as a new building between two older structures; or block infill between porch piers or in an original window opening.

Jack arch (see Flat arch).

Light A section of a window, the pane of glass.

Keystone The wedge-shaped top or center member of an arch.

Kneebrace An oversize bracket supporting a cantilevered or projecting element.

Lattice An openwork grill of interlacing wood strips used as screening.

Lintel The horizontal top member of a window, door, or other opening.

Mansard roof A roof with a double slope on all four sides, with the lower slope being almost vertical and the upper almost horizontal.

Masonry Exterior wall construction of brick, stone or adobe laid up in small units.

Massing The three-dimensional form of a building.

Metal standing-seam roof A roof composed of overlapping sections of metal such as copper-bearing steel or iron coated with a thin alloy of lead and tin. These roofs were attached or crimped together in various raised seams for which the roof is named.

Modillion A bracket projecting outward horizontally, often in the form of a plain block, ornamenting, or sometimes supporting, the underside of a cornice.

Mortar A mixture of sand, lime, cement, and water used as a binding agent in masonry construction.

Mullion A heavy vertical divider between windows or doors.

Multi-light window A window sash composed of more than one pane of glass.

Muntin A secondary framing member to divide and hold the panes of glass in a multi-light window or glazed door.

Neo-classical style Early 20th century style that combines features of ancient, Renaissance, and Colonial architecture; characterized by imposing buildings with large columned porches.

Oriel window A bay window which emerges above the ground floor level.

Paired columns Two columns supported by one pier, as on a porch.

Palladian window A window with three openings, the central one arched and wider than the flanking ones.

Paneled door A door composed of solid panels (either raised or recessed) held within a framework of rails and stiles.

Parapet A low horizontal wall at the edge of a flat roof.

Pediment A triangular crowning element forming the gable of a roof; any similar triangular element used over windows, doors, etc.

Pier A vertical structural element, square or rectangular in cross-section.

Pilaster A square pillar attached, but projecting from a wall, resembling a classical column.

Pitch The degree of the slope of a roof.

Porte-cochere A porch large enough to extend over a driveway.

Portico A roofed space, open or partly enclosed, forming the entrance and centerpiece of the facade of a building, often with columns and a pediment.

Portland cement Strong, inflexible cement used to bind mortar. (Mortar or patching materials with a high-Portland-cement content should not be used on old buildings. The Portland cement is harder than the masonry, thereby causing serious damage over annual freeze-thaw cycles)

Pressed tin Decorative and functional metalwork made of molded tin used to sheath roofs, bays, and cornices.

Pyramidal roof A roof with four identical sides rising to a central peak.

Quoins Larger stones that mark the corner of a building of brick or stone.

Ridge The top horizontal member of a roof where the sloping surfaces meet.

Rusticated masonry Roughened stonework or concrete blocks to give greater articulation to each block.

Sailor course A row of horizontal brick headers used as a lintel, sill, or as a belt course.

Sash The moveable framework containing the glass in a window.

Segmental arch An arch whose profile or radius is less than a semicircle.

Semi-circular arch An arch whose profile or radius is a half-circle the diameter of which equals the opening width.

Sheathing An exterior covering of boards of other surface applied to the frame of the structure. (see Siding)

Shed roof A gently pitched, almost flat roof with only one slope.

Sidelight A vertical area of fixed glass on either side of a door or window.

Siding The exterior wall covering or sheathing of a structure.

Sill The bottom crosspiece of a window frame.

Soldier course A row of vertical brick headers used as a lintel, sill, or belt course.

Spoiling Loss of fragments such as stone, metal, concrete, glass, or a ceramic product from a face or edge due to weathering.

Spindles Slender, elaborately turned wood dowels or rods often used in screens and porch trim.

Stack bond In brickwork, a bond in which the facing brick is laid with all vertical joints continuously aligned. In stone veneer masonry, a pattern in which units of a single size are set with continuous vertical and horizontal joints.

Streetscape The overall facade, not of a single structure, but of the many buildings that define the street.

Surround An encircling border or decorative frame, usually at windows or doors.

Swag Carved ornament in the form of a cloth draped over supports, or in the form of a garland of fruits and flowers.

Terra Cotta Cast and fired clay units, used as ornamentation and set in the masonry construction of a building

Transom A horizontal opening or window over a door or window.

Trim The decorative framing of openings and other features on a facade.

Turret A small slender tower.

Veranda A covered porch or balcony on a building's exterior.

Vergeboard The horizontal face board following and set under the roof edge of a gable, sometimes decorated by carving.

Vernacular A regional form or adaptation of an architectural style.

Wall dormer Dormer created by the upward extension of a wall and a breaking of the roofline.

Water table A projecting horizontal ledge, intended to prevent water from running down the face of a wall's lower section.

Weatherboard Wood siding consisting of overlapping boards usually thicker at the lower edge than the upper (also called clapboard).

APPENDIX D

PRESERVATION RESOURCES

The following resources are available to be used at the Preservation Office of the Joint City-County Planning Commission of Nelson County.

Secretary of the Interior's Standards for Rehabilitation (National Park Service)

Secretary of the Interior's Standards for the Treatment of Historic Properties (National Park Service)

Kentucky Historic Façade Rehabilitation Guidelines (Kentucky Heritage Council)

Preservation Briefs (National Park Service)

Color palettes for architectural periods and styles

Exterior paint selection software

Reference books on historic architecture

Reference books on traditional construction techniques

Manufacturer's catalogs

APPENDIX E

THE SECRETARY OF THE INTERIOR'S STANDARDS FOR REHABILITATION

1. A property shall be used for its historic purpose or be placed in a new use that requires minimal change to the defining characteristics of the building and its site and environment.
2. The historic character of a property shall be retained and preserved. The removal of historic materials or alteration of features and spaces that characterize a property shall be avoided.
3. Each property shall be recognized as a physical record of its time, place, and use. Changes that create a false sense of historical development, such as adding conjectural features or architectural elements from other buildings, shall not be undertaken.
4. Most properties change over time; those changes that have acquired historical significance in their own right shall be retained and preserved.
5. Distinctive features, finishes, and construction techniques or examples of craftsmanship that characterize a historic property shall be preserved.
6. Deteriorated historic features shall be repaired rather than replaced. Where the severity of deterioration requires replacement of a distinctive feature, the new feature shall match the old in design, color, texture, and other visual qualities and, where possible, materials. Replacement of missing features shall be substantiated by documentary, physical, or pictorial evidence.
7. Chemicals or physical treatments, such as sandblasting, that cause damage to historic materials shall not be used. The surface cleaning of structures, if appropriate, shall be undertaken using the gentlest means possible.
8. Significant archaeological resources affected by a project shall be protected and preserved. If such resources must be disturbed, mitigation measures shall be undertaken.
9. New additions, exterior alterations, or related new construction shall not destroy historic materials that characterize the property. The new work shall be differentiated from the old and shall be compatible with the massing, size, scale, and architectural features to protect the historic integrity of the property and its environment.
10. New additions and adjacent or related new construction shall be undertaken in such a manner that if removed in the future, the essential form and integrity of the historic property and its environment would be unimpaired.